

<b>Capabilities</b>	ABOUT QA1	Page 2
	CUSTOM PRODUCTS	Page 4
	ADVANCED MATERIALS	Page 5
	SHOCK ABSORBERS	Page 6



<b>Inch Rod Ends</b>	OVERVIEW	Page 7	
	LOADER SLOT		
	XM/XF	• Alloy Steel - High Strength - Wear Resistant Molded Race	Page 8
	EXM/EXF	• Carbon Steel - Wear Resistant Molded Race	Page 9
	AM/AF	• Aluminum - Wear Resistant Molded Race	Page 10
	2-PIECE		
	GM-T/GF-T	• Stainless Steel - Corrosion Resistant - PTFE Lined	Page 11
	CM/CF	• Carbon Steel - Metal-to-Metal	Page 12
	CM-T/CF-T	• Carbon Steel - PTFE Lined	Page 13
	PCM/PCM-T	• Alloy Steel - High Strength - PTFE Lined Optional	Page 14
	PCYM-T/PCYF-T	• Alloy Steel - High Strength - High Misalignment - PTFE Lined	Page 15
	3-PIECE		
	HM/HF	• Alloy Steel - High Strength - Wear Resistant Alloy Steel Race	Page 16
	HM-T/HF-T	• Alloy Steel - Corrosion Resistant Stainless Steel Race - PTFE Lined	Page 17
	KM/KF	• Carbon Steel - Wear Resistant Alloy Steel Race	Page 18
	KM-T/KF-T	• Carbon Steel - Corrosion Resistant Stainless Steel Race - PTFE Lined	Page 19
	KM/KF LARGE BORE	• Carbon Steel - Wear Resistant Alloy Steel Race	Page 20
	VM/VF	• Carbon Steel - Bronze Race - Self-Lubricating	Page 20
	INJECTION MOLDED		
	NM/NF	• Carbon Steel - Nylon Race - Self-Lubricating	Page 21

<b>Metric Rod Ends</b>	LOADER SLOT		
	MXM/MXF	• Alloy Steel - High Strength - Wear Resistant Molded Race	Page 22
	2-PIECE		
	MGM-T/MGF-T	• Stainless Steel - Corrosion Resistant - PTFE Lined	Page 23
	MCM/MCF	• Carbon Steel - Metal-to-Metal	Page 24
	3-PIECE		
	MHM/MHF	• Alloy Steel - High Strength - Wear Resistant Alloy Steel Race	Page 25
	MHM-T/MHF-T	• Alloy Steel - High Strength - Corrosion Resistant Stainless Steel Race - PTFE Lined	Page 26
	MVM/MVF	• Carbon Steel - Bronze Race - Self-Lubricating	Page 27

# TABLE OF CONTENTS



GEZ Series



COM(-T), HCOM(-T), COM-SS  
& MCOM(-T) Series



MIB/AIB/SIB(-T) Series



WPB-T, WPB-TG  
& NPB-T Series



YPB-T Series

## Inch Spherical Bearings

OVERVIEW		Page 28
GEZ & GEZ-2RS	• Bearing Steel - Fractured Race - Higher Load - Longer Life	Page 29
COM(-T), HCOM(-T)	• Alloy Steel - Metal-to-Metal - PTFE Lined Optional	Page 30
COM-SS	• Stainless Steel - Metal-to-Metal	Page 30
WPB-T & WPB-TG	• Stainless Steel - Wide Race - Corrosion Resistant - Staking Groove Optional - PTFE Lined	Page 31
NPB-T	• Stainless Steel - Narrow Race - Corrosion Resistant - PTFE Lined	Page 32
YPB-T	• Stainless Steel - High Misalignment Ball - Corrosion Resistant - PTFE Lined	Page 32
MIB(-T), AIB(-T) & SIB(-T)	• High Strength - Alternative Construction - PTFE Lined Optional	Page 33

## Metric Spherical Bearings

MCOM(-T)	• Alloy Steel - PTFE Lined Optional	Page 34
----------	-------------------------------------	---------

## Related Products



Racing Ball Joints



Industrial Ball Joints



Linkage Adjusters



Linkage Rods



Clevises



Rod Eyes



Spacers



Tube Adapters



Weld-On Wrench Hexes



Jam Nuts

OVERVIEW		Page 35
RACING BALL JOINTS	• Wear Resistant	Page 37
INDUSTRIAL BALL JOINTS	• Carbon Steel & Stainless Steel - Staked Design & Quick Disconnect Style	Page 39
LINKAGE RODS	• Carbon Steel & Stainless Steel	Page 41
LINKAGE ADJUSTERS	• Alloy Steel & Aluminum	Page 42
CLEVISES	• Carbon Steel - Corrosion Resistant Coating	Page 43
ROD EYES	• Carbon Steel - Non-Misalignment	Page 43
SPACERS	• Stainless Steel - Standard & High Misalignment	Page 44
TUBE ADAPTERS	• Alloy Steel - CNC Machined - Right & Left Hand Threads	Page 45
WELD-ON WRENCH HEXES	• Carbon Steel - Fits Several O.D. Tube Sizes	Page 46
JAM NUTS	• Carbon Steel & Aluminum	Page 46

## Technical Information

STUD & GREASE FITTING CONFIGURATIONS	Page 47
RADIAL & AXIAL STATIC LOAD RATINGS	Page 48
ANGLE OF MISALIGNMENT	Page 49
INCH & METRIC CONVERSIONS TABLE	Page 50
SUGGESTED HOUSING BORES	Page 51
PRODUCT INTERCHANGE GUIDE	Page 52
PART NUMBER REFERENCE GUIDE	Page 53
CALIFORNIA PROPOSITION 65	Page 54
QA1 TECHNICAL SUPPORT	Page 55
TERMS & CONDITIONS OF SALE	Page 56



## THE QA1 ADVANTAGE

Founded in 1993, QA1 Precision Products, Inc. is a manufacturer located in Lakeville, MN. We offer rod ends, spherical bearings, ball joints, suspension components, carbon fiber driveshafts, custom linkages and similar products. Our products are utilized in a variety of markets including agricultural, motorsports, lawn and garden, and construction, among others. QA1 has the largest selection in the industry, economical prices, unmatched quality and a huge inventory with same-day shipments. Our expert engineering, design and quality control personnel, coupled with our international manufacturing alliances, allow us to lead the way in providing quality and consistent products at competitive prices.



# THE QA1 ADVANTAGE



## QUALITY

Our focus at QA1 is being #1 when it comes to quality and affordability. QA1's quality system is ISO 9001 certified, and this focus on quality has enabled us to achieve prominence in the supply of connection components to OEM contract manufacturers and the industrial and racing industries. We follow strict processes, use precision machinery and inspect all of our products to ensure the quality meets our high standards. Our efficient manufacturing processes keep costs down which, in turn, we pass on to our customers.



## EXPERTISE

QA1 was founded over 25 years ago and we're continuously building on our knowledge and expertise, positioning ourselves as one of the most dominant companies in the industry. Powered by a complete team of engineers, machinists and quality inspectors, QA1 has the skills and ability to ensure you're getting the quality parts you need that are designed with unmatched strength, longevity, and consistency.

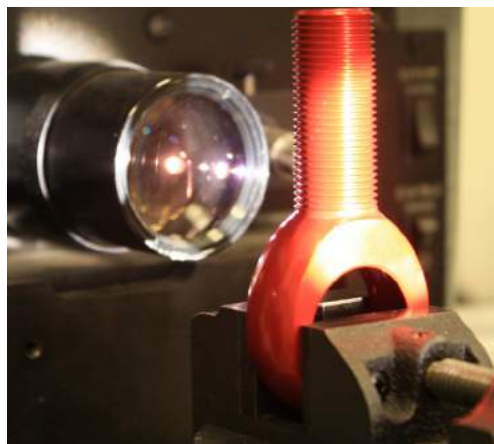

## UNMATCHED SELECTION

With over 6,500 SKUs, QA1 has the selection to fit any need. We offer a variety of connection components, including rod eyes, linkage adjusters, ball joints, shock absorbers, tube adapters, spacers, custom products and more. Our rod ends are offered in a variety of inch and metric sizes, materials and styles, including loader slot, 2-piece, 3-piece and injection molded designs, male and female styles, and right and left hand threads. QA1 also has a large selection of spherical bearings in a variety of in and metric sizes, styles and materials, with or without PTFE liners, for countless applications. Whatever it is that you need to connect, you can find the right linkages at QA1.



## DESIGNED SPECIFICALLY FOR YOUR PROJECT

QA1 has the industry experience and engineering expertise that allows us to design and manufacture custom sub-assemblies for a variety of suspension applications. QA1 routinely supplies assemblies that include products such as:

- Shock Absorbers
- Welded Tubular Sub Frames
- Tubular Suspension Arms
- Carbon Fiber Driveshafts
- Knuckle Castings
- Wheel Bearings and Seals
- Wheel Hubs
- Stainless Steel Brake Discs
- Forged Aluminum Brake Calipers
- Suspension Bushings
- Other Tubular Suspension Components and Linkages

QA1 has worked with numerous customers from product concept to design, development and production of many distinct items. The investments made by QA1, both in the United States and abroad, have resulted in the manufacturing of forgings, sand and investment castings, rubber and injected-molded parts and a variety of other parts and processes. Whether in QA1's Lakeville, Minnesota facility or internationally with one of our global partners, QA1 will provide you with the quality custom product you need. See page 55 for ordering information.

## SAMPLE MARKETS INCLUDE:



**SOLAR**



**GOVERNMENT/MILITARY**



**OUTDOOR POWER EQUIPMENT**



**MOBILITY CHAIRS**



**AGRICULTURAL**



**PACKAGING EQUIPMENT**

## CUSTOM COMPOSITE MATERIAL PRODUCTS

QA1's continuous innovation and growth has led to the development of our Advanced Materials Division, which offers several composite material products for the high performance automotive and industrial markets. Working with advanced materials such as carbon fiber and s-glass, QA1's expert staff utilizes industry experience and works with customers in the design and manufacturing of unique composite products. With our state-of-the-art in-house advanced materials lab with complete design and testing abilities, you can trust you're getting a superior product. See page 55 for ordering information.

### RAISING THE BAR

QA1 is redefining industry standards by performing our filament winding in-house in our Lakeville, Minnesota facility. This allows us to customize tube length, thickness and pattern, enabling products such as carbon fiber driveshafts to be designed and wound for specific applications. QA1 designs, engineers and manufactures unique composite components, enabling the customization of tube dimensions for customer requirements.

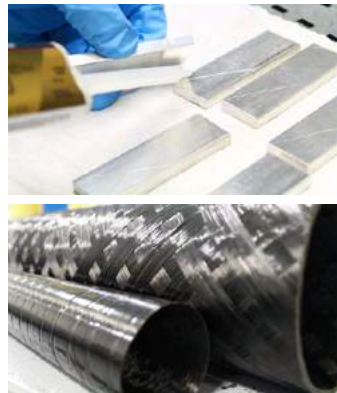

### QUALITY MATERIALS

QA1 manufactures products with materials of the highest quality. In our Advanced Materials Division, we work with carbon fiber, s-glass, e-glass, and more to ensure the best materials are being used, giving you stronger, more consistent products. By using these advanced materials, you can rest assured our composite components can withstand the type of use and environments common to these products.



### CUTTING-EDGE CAPABILITIES

Our advanced materials components are engineered, tested and manufactured in our state-of-the-art advanced materials lab in our Lakeville, Minnesota facility. Equipped with sophisticated 3D modeling programs and machines such as a torsional dyno, balancer, tensile tester, filament winder, robotic welding, coordinate measuring machines, CNC machines and tube benders, we're able to take your project from initial design concept to complete assembly, all under one roof.



## SHOCK ABSORBERS FOR THE OE MARKET

QA1 has manufactured a variety of shock absorbers and struts for commercial and industrial OE markets. We work with customers to help design and manufacture exercise equipment, commercial lawn and garden equipment, neighborhood electric vehicles and commercial utility vehicles.

QA1 provides engineering assistance to the OE markets and can assist in determining the valving characteristics needed for your application. To start your development program, our engineers need to know the installed compressed and extended lengths and type of mounting needed for your application. We have test sample kits available that are field-tunable and provide adjustment of both compression and rebound rates. You install the shock or strut, tune and adjust to your requirements and return the tuned shock or strut to QA1 for evaluation. We then duplicate your developed force requirements specific to your individual application. Minimum quantities apply. See page 55 for ordering information.



Military



Commercial Mower for  
Floating Lower Deck



Commercial Utility  
Vehicle



Electric  
Vehicle

## SHOCK ABSORBERS FOR THE PERFORMANCE MARKET

QA1 is a leader in manufacturing shock absorbers and struts for the racing and high performance aftermarkets, including circle track racing, drag racing, street performance, autocrossing and hot rodding applications. We offer circle track shocks in both twin tube and monotube configurations in several sizes, lengths, mounting styles and compression rates for dirt and asphalt track cars. We also offer drag racing and street performance shocks and struts in styles from custom mount to stock mount as well as coil-over and non-coil-over, all available in steel and aluminum. A variety of valving options are available, including non-adjustable, single adjustable, double adjustable, 4-way adjustable and drag "R" series. QA1 also offers a complete line of coil-over springs to complement its line of high performance shocks and struts that are available in a variety of spring I.D.s and lengths, which are either chrome plated or silver powder coated.



# ROD ENDS OVERVIEW

# QA1

With the largest selection in the industry, economical prices, unmatched quality and a huge inventory, QA1 has a rod end for every need. QA1 offers inch and metric rod ends in a variety of sizes, materials, configurations, coatings and options, including:

- Aluminum, Alloy & Carbon Steel
- Male & Female
- Metric & Inch
- High Misalignment
- Stud Configurations
- Self-Lubricating
- Grease Fittings
- Protective Coating
- Custom Applications

## LOADER SLOT ROD ENDS



Cross-Sectional View

QA1 began offering this loader slot style rod end in 1995. The rod end ball is inserted into a machined slot, which is then surrounded by injection molded reinforced PTFE. This serves as a liner to keep dirt and debris out while also lubricating the rod end. In addition to providing added strength, the injection molded race won't pound out like traditional PTFE liners, increasing the longevity of your rod ends.

Strong and durable, these rod ends are a good choice for most applications.

### INCH SERIES

- XM & XF - Alloy Steel
- EXM & EXF - Carbon Steel
- AM & AF - Aluminum6+30

### METRIC SERIES

- MXM & MXF - Alloy Steel



## 2-PIECE ROD ENDS

QA1's 2-piece metal-to-metal style rod ends, commonly referred to as a Mohawk design, have only two components: the ball and the body. The body is swaged around the ball on each side to lock it in, and then loosened.

Very economical, they're commonly used in light duty applications.

### INCH SERIES

- GM-T & GF-T - Stainless Steel - PTFE Lined
- CM & CF - Carbon Steel
- CM-T & CF-T - Carbon Steel - PTFE Lined
- PCM & PCM-T - Alloy Steel - PTFE Lined Optional
- PCYM-T & PCYF-T - Alloy Steel - High Misalignment - PTFE Lined

### METRIC SERIES

- MGM-T & MGF-T - Stainless Steel - PTFE Lined
- MCM & MCF - Carbon Steel



## 3-PIECE ROD ENDS

In QA1's 3-piece precision rod ends, the ball is pressed into a sleeve that is swaged around the ball. This whole insert is then staked into a rod end body. This unit offers better ball-to-race conformity for tighter tolerances.

Great choice for high load, high oscillation applications that require tighter tolerances.

### INCH SERIES

- HM & HF - Alloy Steel
- HM-T & HF-T - Alloy Steel - PTFE Lined
- KM & KF - Carbon Steel
- KM-T & KF-T - Carbon Steel - PTFE Lined
- KM/KF Large Bore - Carbon Steel
- VM & VF - Carbon Steel

### METRIC SERIES

- MHM & MHF - Alloy Steel
- MHM-T & MHF-T - Alloy Steel - PTFE Lined
- MVM & MVF - Carbon Steel



## INJECTION MOLDED ROD ENDS

QA1's injection molded carbon steel rod ends feature a nylon self-lubricating, reinforced race compound designed to provide low friction, low moisture absorbing properties for high wear resistance. They are protective coated for corrosion resistance.

Good choice for low load, moderate oscillation applications.

### INCH SERIES

- NM & NF - Carbon Steel





## **XM & XF ALLOY STEEL**

**Self-Lubricating Race - Right & Left Hand Threads - Male & Female**

**U L T R A H I G H S T R E N G T H**

Inch Rod Ends

### XM & XF Features

**BALL**

- 52100 Bearing Steel
- Heat Treated
- Hard Chrome Plated
- Precision Ground

**RACE**

- Reinforced Nylon 12 with PTFE

**BODY**

- Alloy Steel
- Heat Treated
- Protective Coated for Corrosion Resistance

**EXCLUSIVE FEATURES**

- Metal-to-Metal Support for Heavy Shock Loads
- Increased Cross-Sectional Thickness for Greater Tensile Strength

**PART NUMBER**

**DIMENSIONS IN INCHES**

### XM Male

Right Hand	Left Hand	B + .0015 - .0005	W ± .005	T ± .005	A ± .015	D ± .010	Ball Dia. Ref.	C + .062 - .031	Thread UNF-3A	Misalign. Angle a°	Ult. Radial Static Load Lbs.	Approx. Brg. Wgt. Lbs.
XMR3	XML3	0.1900	0.312	0.250	1.250	0.625	0.437	0.750	10-32	13	2,851	0.03
XMR4	XML4	0.2500	0.375	0.281	1.562	0.750	0.500	1.000	1/4-28	16	5,260	0.04
XMR4-5	XML4-5	0.2500	0.375	0.281	1.875	0.875	0.500	1.250	5/16-24	13	8,452	0.07
XMR5	XML5	0.3125	0.437	0.344	1.875	0.875	0.625	1.250	5/16-24	14	7,639	0.07
XMR5-6	XML5-6	0.3125	0.437	0.344	1.938	1.000	0.625	1.250	3/8-24	12	10,382	0.11
XMR6	XML6	0.3750	0.500	0.406	1.938	1.000	0.719	1.250	3/8-24	12	9,544	0.11
XMR6-7	XML6-7	0.3750	0.500	0.406	2.125	1.125	0.719	1.375	7/16-20	10	14,006	0.15
XMR7	XML7	0.4375	0.562	0.437	2.125	1.125	0.812	1.375	7/16-20	14	10,285	0.15
XMR7-8	XML7-8	0.4375	0.562	0.437	2.438	1.312	0.812	1.500	1/2-20	12	18,761	0.24
XMR8	XML8	0.5000	0.625	0.500	2.438	1.312	0.937	1.500	1/2-20	12	16,238	0.24
XMR8-10	XML8-10	0.5000	0.625	0.500	2.625	1.500	0.937	1.625	5/8-18	10	23,542	0.36
XMR8-12	XML8-12	0.5000	0.750	0.562	2.875	1.750	0.937	1.750	3/4-16	16	32,457	0.42
XMR10	XML10	0.6250	0.750	0.562	2.625	1.500	1.125	1.625	5/8-18	16	17,955	0.36
XMR10-12	XML10-12	0.6250	0.750	0.562	2.875	1.750	1.125	1.750	3/4-16	13	31,680	0.57
XMR12	XML12	0.7500	0.875	0.687	2.875	1.750	1.312	1.750	3/4-16	14	28,081	0.57
XMR12-14	XML12-14	0.7500	0.875	0.687	3.375	2.000	1.312	1.875	7/8-14	12	43,486	0.88
XMR14	XML14	0.8750	0.875	0.765	3.375	2.000	1.375	2.000	7/8-14	7	45,051	0.88
XMR16	XML16	1.0000	1.375	1.000	4.125	2.750	1.875	2.125	1 1/4-12	17	76,200	2.41
XMR16-1	XML16-1	1.0000	1.375	1.000	4.125	2.750	1.875	2.125	1-14*	17	76,200	2.13
XMR16-2	XML16-2	1.0000	1.375	1.000	4.125	2.750	1.875	2.125	1-12	17	76,200	2.13

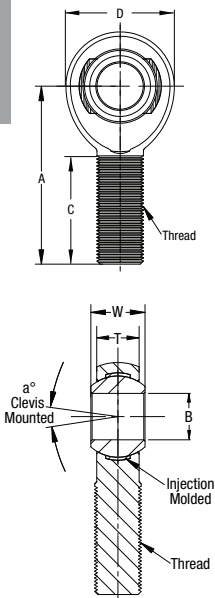

### SELF-LUBRICATING

**PART NUMBER**

**DIMENSIONS IN INCHES**

### XF Female

Right Hand	Left Hand	B + .0015 - .0005	W ± .005	T ± .005	A ± .015	D ± .010	E ± .010	F ± .010	Ball Dia. Ref.	C + .062 - .031	Thread UNF-2B	Misalign. Angle a°	Ult. Radial Static Load Lbs.	Approx. Brg. Wgt. Lbs.
XFR3	XFL3	0.1900	0.312	0.250	1.062	0.625	0.406	0.312	0.437	0.562	10-32	13	3,733	0.04
XFR4	XFL4	0.2500	0.375	0.281	1.312	0.750	0.469	0.375	0.500	0.750	1/4-28	16	6,190	0.06
XFR5	XFL5	0.3125	0.437	0.344	1.375	0.875	0.500	0.437	0.625	0.750	5/16-24	14	7,639	0.09
XFR6	XFL6	0.3750	0.500	0.406	1.625	1.000	0.687	0.562	0.719	0.937	3/8-24	12	9,544	0.14
XFR7	XFL7	0.4375	0.562	0.437	1.812	1.125	0.750	0.625	0.812	1.062	7/16-20	14	10,285	0.19
XFR8	XFL8	0.5000	0.625	0.500	2.125	1.312	0.875	0.750	0.937	1.187	1/2-20	12	15,336	0.31
XFR10	XFL10	0.6250	0.750	0.562	2.500	1.500	1.000	0.875	1.125	1.500	5/8-18	16	17,955	0.45
XFR12	XFL12	0.7500	0.875	0.687	2.875	1.750	1.125	1.000	1.312	1.750	3/4-16	14	28,081	0.69
XFR16	XFL16	1.0000	1.375	1.000	4.125	2.750	1.625	1.500	1.875	2.125	1 1/4-12	17	76,200	2.11
XFR16-1	XFL16-1	1.0000	1.375	1.000	4.125	2.750	1.625	1.500	1.875	2.125	1-14*	17	76,200	2.58
XFR16-2	XFL16-2	1.0000	1.375	1.000	4.125	2.750	1.625	1.500	1.875	2.125	1-12	17	76,200	2.58

### SELF-LUBRICATING

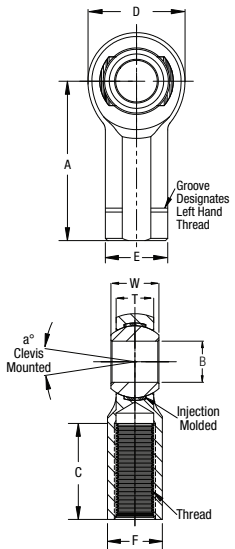

This design results in metal-to-metal support for heavy shock loads, and smooth operation for low loads. X Series rod ends are appropriate and provide the best performance for most applications. This series is moderately priced.

# EXM & EXF CARBON STEEL

Self-Lubricating Race - Right & Left Hand Threads - Male & Female

**H I G H S T R E N G T H**

**Inch  
Endura  
Loader Slot  
Rod Ends**

**QA1**

## EXM & EXF Features

### BALL

- 52100 Bearing Steel
- Heat Treated
- Hard Chrome Plated
- Precision Ground

### RACE

- Reinforced Nylon 12 with PTFE

### BODY

- Carbon Steel (Alloy Steel - Mfr.'s Option)
- Protective Coated for Corrosion Resistance

### EXCLUSIVE FEATURES

- Metal-to-Metal Support for Heavy Shock Loads
- Increased Cross-Sectional Thickness for Greater Tensile Strength

### PART NUMBER

### DIMENSIONS IN INCHES

## EXM Male

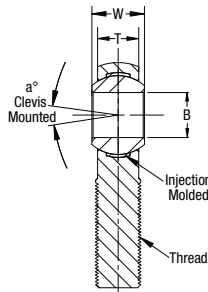
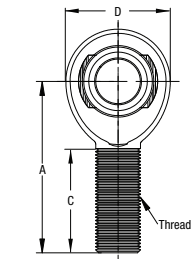

Right Hand	Left Hand	B + .0015 - .0005	W ± .005	T ± .005	A ± .015	D ± .010	Ball Dia. Ref.	C + .062 - .031	Thread UNF-3A	Misalign. Angle a°	Ult. Radial Static Load Lbs.	Approx. Brg. Wgt. Lbs.
EXMR3	EXML3	0.1900	0.312	0.250	1.250	0.625	0.437	0.750	10-32	13	1,169	0.03
EXMR4	EXML4	0.2500	0.375	0.281	1.562	0.750	0.500	1.000	1/4-28	16	2,158	0.04
EXMR4-5	EXML4-5	0.2500	0.375	0.281	1.875	0.875	0.500	1.250	5/16-24	13	3,467	0.07
EXMR5	EXML5	0.3125	0.437	0.344	1.875	0.875	0.625	1.250	5/16-24	14	2,784	0.07
EXMR6	EXML6	0.3750	0.500	0.406	1.938	1.000	0.719	1.250	3/8-24	12	3,915	0.11
EXMR6-7	EXML6-7	0.3750	0.500	0.406	2.125	1.125	0.719	1.375	7/16-20	10	7,180	0.15
EXMR7	EXML7	0.4375	0.562	0.437	2.125	1.125	0.812	1.375	7/16-20	14	4,218	0.15
EXMR7-8	EXML7-8	0.4375	0.562	0.437	2.438	1.312	0.812	1.500	1/2-20	12	9,620	0.24
EXMR8	EXML8	0.5000	0.625	0.500	2.438	1.312	0.937	1.500	1/2-20	12	10,001	0.24
EXMR8-10	EXML8-10	0.5000	0.625	0.500	2.625	1.500	0.937	1.625	5/8-18	10	12,807	0.36
EXMR10	EXML10	0.6250	0.750	0.562	2.625	1.500	1.125	1.625	5/8-18	16	11,226	0.36
EXMR10-12	EXML10-12	0.6250	0.750	0.562	2.875	1.750	1.125	1.750	3/4-16	13	18,000	0.57
EXMR12	EXML12	0.7500	0.875	0.687	2.875	1.750	1.312	1.750	3/4-16	14	16,565	0.57
EXMR14	EXML14	0.8750	0.875	0.765	3.375	2.000	1.375	2.000	7/8-14	7	22,843	0.88
EXMR16	EXML16	1.0000	1.375	1.000	4.125	2.750	1.875	2.125	1 1/4-12	17	43,541	2.41
EXMR16-1	EXML16-1	1.0000	1.375	1.000	4.125	2.750	1.875	2.125	1-14*	17	43,541	2.13
EXMR16-2	EXML16-2	1.0000	1.375	1.000	4.125	2.750	1.875	2.125	1-12	17	43,541	2.13

**SELF-LUBRICATING**

### PART NUMBER

### DIMENSIONS IN INCHES

## EXF Female

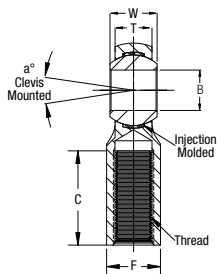
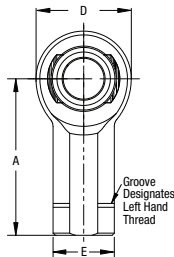

Right Hand	Left Hand	B + .0015 - .0005	W ± .005	T ± .005	A ± .015	D ± .010	E ± .010	F ± .010	Ball Dia. Ref.	C + .062 - .031	Thread UNF-2B	Misalign. Angle a°	Ult. Radial Static Load Lbs.	Approx. Brg. Wgt. Lbs.
EXFR4	EXFL4	0.2500	0.375	0.281	1.312	0.750	0.469	0.375	0.500	0.750	1/4-28	16	2,539	0.06
EXFR5	EXFL5	0.3125	0.437	0.344	1.375	0.875	0.500	0.437	0.625	0.750	5/16-24	14	3,133	0.09
EXFR6	EXFL6	0.3750	0.500	0.406	1.625	1.000	0.687	0.562	0.719	0.937	3/8-24	12	3,915	0.14
EXFR7	EXFL7	0.4375	0.562	0.437	1.812	1.125	0.750	0.625	0.812	1.062	7/16-20	14	4,218	0.19
EXFR8	EXFL8	0.5000	0.625	0.500	2.125	1.312	0.875	0.750	0.937	1.187	1/2-20	12	10,001	0.31
EXFR10	EXFL10	0.6250	0.750	0.562	2.500	1.500	1.000	0.875	1.125	1.500	5/8-18	16	11,226	0.45
EXFR12	EXFL12	0.7500	0.875	0.687	2.875	1.750	1.125	1.000	1.312	1.750	3/4-16	14	16,848	0.69
EXFR16	EXFL16	1.0000	1.375	1.000	4.125	2.750	1.625	1.500	1.875	2.125	1 1/4-12	17	43,541	2.28
EXFR16-1	EXFL16-1	1.0000	1.375	1.000	4.125	2.750	1.625	1.500	1.875	2.125	1-14*	17	43,541	2.58
EXFR16-2	EXFL16-2	1.0000	1.375	1.000	4.125	2.750	1.625	1.500	1.875	2.125	1-12	17	43,541	2.58

**SELF-LUBRICATING**

This design results in metal-to-metal support for heavy shock loads and smooth operation for low loads. EX series rod ends are appropriate for many applications. When greater strength is required, refer to the X series rod ends on page 8. The EX Series rod ends are economically priced.



# GM-T & GF-T Stainless Steel

PTFE Lined - Right & Left Hand Threads - Male & Female

**C O M M E R C I A L**

Inch  
2-Piece  
Rod Ends

**QA1**

## GM-T & GF-T

### Features

#### BALL

- 440C Stainless Steel
- Heat Treated

- Hard Chrome Plated
- Precision Ground

#### BODY

- 300 Series Stainless Steel
- PTFE Lined

#### PART NUMBER

#### DIMENSIONS IN INCHES

### GM-T Male

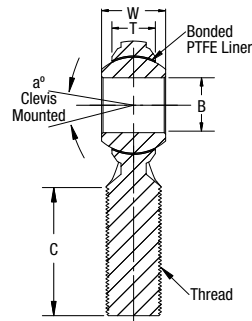
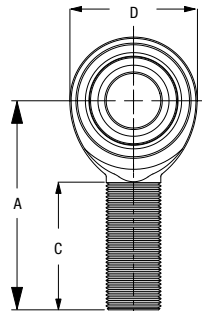

Right Hand	Left Hand	B + .0015 - .0005	W ± .005	T Ref.	A ± .015	D ± .010	Ball Dia. Ref.	C + .062 - .031	Thread UNF-3A	Misalign. Angle a°	Ult. Radial Static Load Lbs.	Approx. Brg. Wgt. Lbs.
GMR3T	GML3T	0.1900	0.312	0.234	1.250	0.625	0.437	0.750	10-32	20	1,190	0.03
GMR4T	GML4T	0.2500	0.375	0.250	1.562	0.750	0.500	1.000	1/4-28	27	2,165	0.04
GMR5T	GML5T	0.3125	0.437	0.312	1.875	0.875	0.625	1.250	5/16-24	22	3,278	0.07
GMR6T	GML6T	0.3750	0.500	0.359	1.938	1.000	0.719	1.250	3/8-24	22	4,527	0.11
GMR7T	GML7T	0.4375	0.562	0.406	2.125	1.125	0.812	1.375	7/16-20	21	5,689	0.15
GMR8T	GML8T	0.5000	0.625	0.453	2.438	1.312	0.937	1.500	1/2-20	20	7,352	0.24
GMR10T	GML10T	0.6250	0.750	0.484	2.625	1.500	1.125	1.625	5/8-18	26	8,200	0.36
GMR12T	GML12T	0.7500	0.875	0.593	2.875	1.750	1.312	1.750	3/4-16	24	11,595	0.57

**SELF-LUBRICATING**

#### PART NUMBER

#### DIMENSIONS IN INCHES

### GF-T Female

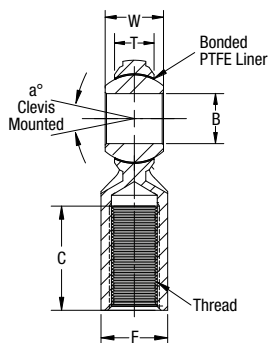
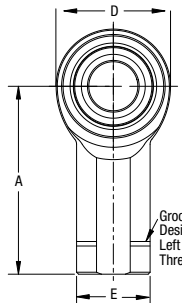

Right Hand	Left Hand	B + .0015 - .0005	W ± .005	T Ref.	A ± .015	D ± .010	E ± .010	F ± .010	Ball Dia. Ref.	C + .062 - .031	Thread UNF-2B	Misalign. Angle a°	Ult. Radial Static Load Lbs.	Approx. Brg. Wgt. Lbs.
GFR3T	GFL3T	0.1900	0.312	0.234	1.062	0.625	0.406	0.312	0.437	0.500	10-32	20	1,190	0.04
GFR4T	GFL4T	0.2500	0.375	0.250	1.312	0.750	0.469	0.375	0.500	0.687	1/4-28	27	2,165	0.05
GFR5T	GFL5T	0.3125	0.437	0.312	1.375	0.875	0.500	0.437	0.625	0.687	5/16-24	22	3,278	0.08
GFR6T	GFL6T	0.3750	0.500	0.359	1.625	1.000	0.687	0.562	0.719	0.812	3/8-24	22	4,527	0.13
GFR7T	GFL7T	0.4375	0.562	0.406	1.812	1.125	0.750	0.625	0.812	0.937	7/16-20	21	5,689	0.18
GFR8T	GFL8T	0.5000	0.625	0.453	2.125	1.312	0.875	0.750	0.937	1.062	1/2-20	20	7,352	0.29
GFR10T	GFL10T	0.6250	0.750	0.484	2.500	1.500	1.000	0.875	1.125	1.375	5/8-18	26	8,200	0.43
GFR12T	GFL12T	0.7500	0.875	0.593	2.875	1.750	1.125	1.000	1.312	1.562	3/4-16	24	11,595	0.65

**SELF-LUBRICATING**

This series features a self-lubricating PTFE liner and a 300 series stainless steel body for corrosive environments.

**CM & CF  
Features**

**BALL**

- 52100 Bearing Steel
- Heat Treated

- Hard Chrome Plated
- Precision Ground

**BODY**

- Carbon Steel
- Protective Coated for Corrosion Resistance

**PART NUMBER**

**DIMENSIONS IN INCHES**

**CM Male**

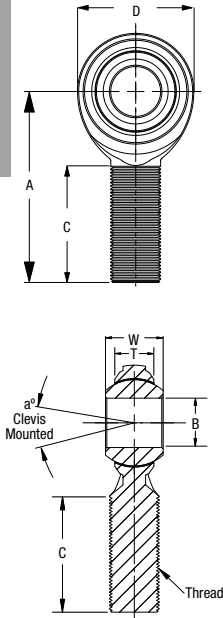

Right Hand	Left Hand	B + .0025 - .0005	W ± .005	T Ref.	A ± .015	D Ref.	Ball Dia. Ref.	C + .062 - .031	Thread UNF-3A	Misalign. Angle a°	Ult. Radial Static Load Lbs.	Approx. Brg. Wgt. Lbs.
CMR2*	CML2*	0.1250	0.250	0.175	0.937	0.500	0.312	0.562	6-32 UNC	22	700	0.01
CMR3*	CML3*	0.1900	0.312	0.234	1.250	0.625	0.437	0.750	10-32	20	1,558	0.03
CMR3-4*	CML3-4*	0.1900	0.312	0.234	1.562	0.750	0.437	1.000	1/4-28	20	3,435	0.04
CMR4*	CML4*	0.2500	0.375	0.250	1.562	0.750	0.500	1.000	1/4-28	27	2,835	0.04
CMR4-5*	CML4-5*	0.2500	0.375	0.250	1.875	0.875	0.500	1.250	5/16-24	27	5,534	0.06
CMR5*	CML5*	0.3125	0.437	0.312	1.875	0.875	0.625	1.250	5/16-24	22	4,517	0.07
CMR5-6*	CML5-6*	0.3125	0.437	0.312	1.938	1.000	0.625	1.250	3/8-24	22	6,853	0.10
CMR6	CML6	0.3750	0.500	0.359	1.938	1.000	0.719	1.250	3/8-24	22	6,323	0.11
CMR6-103	-	0.3750	0.625	0.370	1.938	1.125	0.719	1.211	3/8-24	40	6,162	0.12
CMR6-7	CML6-7	0.3750	0.500	0.359	2.125	1.125	0.719	1.375	7/16-20	22	8,278	0.14
CMR6-8	CML6-8	0.3750	0.500	0.359	2.125	1.125	0.719	1.375	1/2-20	22	8,278	0.17
CMR7	CML7	0.4375	0.562	0.406	2.125	1.125	0.812	1.375	7/16-20	21	7,897	0.15
CMR7-6	-	0.4375	0.562	0.406	2.125	1.125	0.812	1.375	3/8-24	21	7,897	0.13
CMR7-8	CML7-8	0.4375	0.562	0.406	2.438	1.312	0.812	1.500	1/2-20	21	11,191	0.22
CMR8	CML8	0.5000	0.625	0.453	2.438	1.312	0.937	1.500	1/2-20	20	10,046	0.24
CMR8-102	CML8-102	0.5000	1.150	0.453	2.438	1.312	0.937	1.500	1/2-20	26	10,046	0.24
CMR8-10	CML8-10	0.5000	0.625	0.453	2.625	1.500	0.937	1.625	5/8-18	20	13,729	0.34
CMR8-12	CML8-12	0.5000	0.750	0.484	2.625	1.500	1.125	1.625	3/4-16	26	11,385	0.42
CMR10	CML10	0.6250	0.750	0.484	2.625	1.500	1.125	1.625	5/8-18	26	11,385	0.36
CMR10-12	CML10-12	0.6250	0.750	0.484	2.875	1.750	1.125	1.750	3/4-16	26	16,922	0.51
CMR12	CML12	0.7500	0.875	0.593	2.875	1.750	1.312	1.750	3/4-16	24	15,894	0.57
CMR12-757	-	0.7570	0.875	0.593	2.875	1.750	1.312	1.750	3/4-16	24	15,894	0.56

**PART NUMBER**

**DIMENSIONS IN INCHES**

**CF Female**

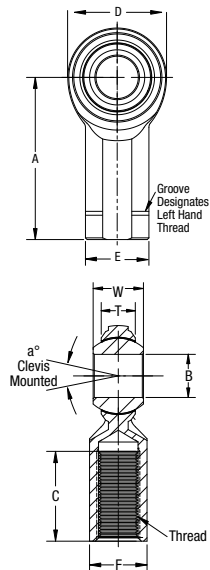

Right Hand	Left Hand	B + .0025 - .0005	W ± .005	T Ref.	A ± .015	D Ref.	E ± .010	F ± .010	Ball Dia. Ref.	C + .062 - .031	Thread UNF-2B	Misalign. Angle a°	Ult. Radial Static Load Lbs.	Approx. Brg. Wgt. Lbs.
CFR2*	CFL2*	0.1250	0.250	0.175	0.812	0.500	0.312	0.250	0.312	0.437	6-32 UNC	22	1,510	0.02
CFR3*	CFL3*	0.1900	0.312	0.234	1.062	0.625	0.406	0.312	0.437	0.500	10-32	20	2,079	0.04
CFR3-4	-	0.1900	0.312	0.234	1.312	0.750	0.469	0.375	0.437	0.687	1/4-28	20	4,197	0.05
CFR4	CFL4	0.2500	0.375	0.250	1.312	0.750	0.469	0.375	0.500	0.687	1/4-28	27	3,820	0.05
CFR5	CFL5	0.3125	0.437	0.312	1.375	0.875	0.500	0.437	0.625	0.687	5/16-24	22	5,110	0.08
CFR5-6	-	0.3125	0.437	0.359	1.625	1.000	0.687	0.562	0.625	0.812	3/8-24	22	6,323	0.10
CFR6	CFL6	0.3750	0.500	0.359	1.625	1.000	0.687	0.562	0.719	0.812	3/8-24	22	6,323	0.13
CFR7	CFL7	0.4375	0.562	0.406	1.812	1.125	0.750	0.625	0.812	0.937	7/16-20	21	7,897	0.18
CFR8	CFL8	0.5000	0.625	0.453	2.125	1.312	0.875	0.750	0.937	1.062	1/2-20	20	10,046	0.29
CFR10	CFL10	0.6250	0.750	0.484	2.500	1.500	1.000	0.875	1.125	1.375	5/8-18	26	11,385	0.43
CFR12	CFL12	0.7500	0.875	0.593	2.875	1.750	1.125	1.000	1.312	1.562	3/4-16	24	15,894	0.65

The C Series is defined as economical, commercial grade rod ends that are generally appropriate for light duty applications.

Load ratings apply only to rod ends without grease fittings. For ratings with grease fittings, please contact us.

# CM-T & CF-T Carbon Steel

PTFE Lined - Right & Left Hand Threads - Male & Female

**C O M M E R C I A L**

Inch  
2-Piece  
Rod Ends

**QA1**

## CM-T & CF-T

### Features

#### BALL

- 52100 Bearing Steel
- Heat Treated

- Hard Chrome Plated
- Precision Ground

#### BODY

- Carbon Steel
- PTFE Lined
- Protective Coated for Corrosion Resistance

#### PART NUMBER

#### DIMENSIONS IN INCHES

### CM-T Male

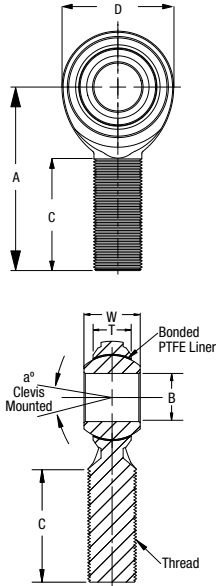

Right Hand	Left Hand	B + .0025 - .0005	W ± .005	T Ref.	A ± .015	D Ref.	Ball Dia. Ref.	C + .062 - .031	Thread UNF-3A	Misalign. Angle a°	Ult. Radial Static Load Lbs.	Approx. Brg. Wgt. Lbs.
CMR3-4T	CML3-4T	0.1900	0.312	0.234	1.562	0.750	0.437	1.000	1/4-28	20	2,233	0.04
CMR4T	CML4T	0.2500	0.375	0.250	1.562	0.750	0.500	1.000	1/4-28	27	1,842	0.04
CMR4-5T	CML4-5T	0.2500	0.375	0.250	1.875	0.875	0.500	1.250	5/16-24	27	3,297	0.06
CMR5T	CML5T	0.3125	0.437	0.312	1.875	0.875	0.625	1.250	5/16-24	22	3,297	0.07
CMR5-6T	CML5-6T	0.3125	0.437	0.312	1.938	1.000	0.625	1.250	3/8-24	22	4,934	0.10
CMR6T	CML6T	0.3750	0.500	0.359	1.938	1.000	0.719	1.250	3/8-24	22	4,552	0.11
CMR6-7T	CML6-7T	0.3750	0.500	0.359	2.125	1.125	0.719	1.375	7/16-20	22	5,795	0.14
CMR6-8T	CML6-8T	0.3750	0.500	0.359	2.125	1.125	0.719	1.375	1/2-20	22	5,795	0.17
CMR7T	CML7T	0.4375	0.562	0.406	2.125	1.125	0.812	1.375	7/16-20	21	5,527	0.15
CMR7-8T	CML7-8T	0.4375	0.562	0.406	2.438	1.312	0.812	1.500	1/2-20	21	7,834	0.22
CMR8T	CML8T	0.5000	0.625	0.453	2.438	1.312	0.937	1.500	1/2-20	20	8,740	0.24
CMR8-10T	CML8-10T	0.5000	0.625	0.453	2.625	1.500	0.937	1.625	5/8-18	20	11,532	0.34
CMR10T	CML10T	0.6250	0.750	0.484	2.625	1.500	1.125	1.625	5/8-18	26	9,563	0.36
CMR10-12T	CML10-12T	0.6250	0.750	0.484	2.875	1.750	1.125	1.750	3/4-16	26	14,214	0.51
CMR12T	CML12T	0.7500	0.875	0.593	2.875	1.750	1.312	1.750	3/4-16	24	13,668	0.57
CMR12T-102*	-	0.7500	1.125	0.593	2.875	1.750	1.312	1.750	3/4-16	34	15,894	0.64
CMR12T-105**	CML12T-105	0.7500	0.875	0.593	3.875	1.750	1.312	2.750	3/4-16	24	21,400	0.66

**SELF-LUBRICATING**

#### PART NUMBER

#### DIMENSIONS IN INCHES

### CF-T Female

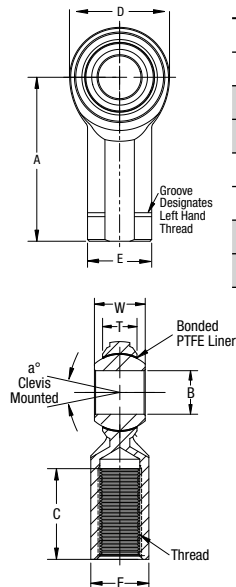

Right Hand	Left Hand	B + .0025 - .0005	W ± .005	T Ref.	A ± .015	D Ref.	E ± .010	F ± .010	Ball Dia. Ref.	C + .062 - .031	Thread UNF-2B	Misalign. Angle a°	Ult. Radial Static Load Lbs.	Approx. Brg. Wgt. Lbs.
CFR3T	CFL3T	0.1900	0.312	0.234	1.062	0.625	0.406	0.312	0.437	0.500	10-32	20	935	0.04
CFR4T	CFL4T	0.2500	0.375	0.250	1.312	0.750	0.469	0.375	0.500	0.687	1/4-28	27	1,842	0.05
CFR5T	CFL5T	0.3125	0.437	0.312	1.375	0.875	0.500	0.437	0.625	0.687	5/16-24	22	3,297	0.08
CFR6T	CFL6T	0.3750	0.500	0.359	1.625	1.000	0.687	0.562	0.719	0.812	3/8-24	22	4,552	0.13
CFR7T	CFL7T	0.4375	0.562	0.406	1.812	1.125	0.750	0.625	0.812	0.937	7/16-20	21	5,527	0.18
CFR8T	CFL8T	0.5000	0.625	0.453	2.125	1.312	0.875	0.750	0.937	1.062	1/2-20	20	8,740	0.29
CFR10T	CFL10T	0.6250	0.750	0.484	2.500	1.500	1.000	0.875	1.125	1.375	5/8-18	26	9,563	0.43
CFR12T	CFL12T	0.7500	0.875	0.593	2.875	1.750	1.125	1.000	1.312	1.562	3/4-16	24	13,668	0.65

**SELF-LUBRICATING**

The C-T Series is defined by economical, self-lubricating, commercial grade rod ends that are generally appropriate for low load, low oscillation applications.

\* Comes with jam nut.

\*\*Made with alloy steel instead of carbon steel.

# PCM & PCM-T Alloy Steel

PTFE Lined Optional - Right & Left Hand Threads - Male

**EXTRA STRENGTH**

**PCM & PCM-T  
Features**

**BALL**

- 52100 Bearing Steel
- Heat Treated

- Hard Chrome Plated
- Precision Ground

**BODY**

- Alloy Steel
- Heat Treated
- Metal-to-Metal
- Black Oxide Coated
- PTFE Lined (PCM-T)

PART NUMBER		DIMENSIONS IN INCHES										
Right Hand	Left Hand	B + .0015 - .0005	W ± .005	T Ref.	A ± .015	D Ref.	Ball Dia. Ref.	C + .062 - .031	Thread UNF-3A	Misalign. Angle a°	Ult. Radial Static Load Lbs.	Approx. Brg. Wgt. Lbs.
PCMR6	PCML6	0.375	0.500	0.359	1.938	1.000	0.719	1.250	3/8-24	22	9500	0.15
PCMR8	PCML8	0.5000	0.625	0.453	2.438	1.312	0.937	1.500	1/2-20	20	17,000	0.24
PCMR8-10	PCML8-10	0.5000	0.625	0.453	2.625	1.500	0.937	1.625	5/8-18	20	19,300	0.30
PCMR10	PCML10	0.6250	0.750	0.484	2.625	1.500	1.125	1.625	5/8-18	26	18,000	0.36
PCMR10-12	PCML10-12	0.6250	0.750	0.484	2.875	1.750	1.125	1.750	3/4-16	26	27,000	0.48
PCMR12	PCML12	0.7500	0.875	0.593	2.875	1.750	1.312	1.750	3/4-16	24	25,000	0.57

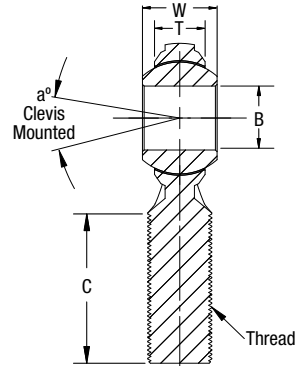
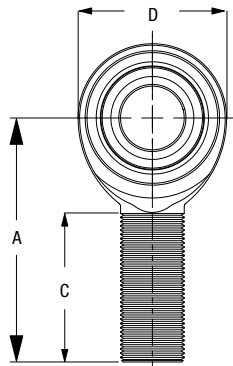

PART NUMBER		DIMENSIONS IN INCHES										
Right Hand	Left Hand	B + .0015 - .0005	W ± .005	T Ref.	A ± .015	D ± .010	Ball Dia. Ref.	C + .062 - .031	Thread UNF-2B	Misalign. Angle a°	Ult. Radial Static Load Lbs.	Approx. Brg. Wgt. Lbs.
PCMR6T	PCML6T	0.375	0.500	0.359	1.938	1.000	0.719	1.250	3/8-24	22	7100	0.15
PCMR8T	PCML8T	0.5000	0.625	0.453	2.438	1.312	0.937	1.500	1/2-20	20	14,500	0.24
PCMR8-10T	PCML8-10T	0.5000	0.625	0.453	2.625	1.500	0.937	1.625	5/8-18	20	17,650	0.30
PCMR10T	PCML10T	0.6250	0.750	0.484	2.625	1.500	1.125	1.625	5/8-18	26	15,200	0.36
PCMR10-12T	PCML10-12T	0.6250	0.750	0.484	2.875	1.750	1.125	1.750	3/4-16	26	23,000	0.48
PCMR12T	PCML12T	0.7500	0.875	0.593	2.875	1.750	1.312	1.750	3/4-16	24	21,400	0.57

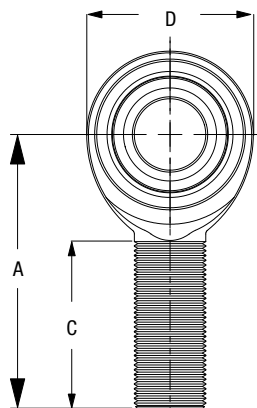

**SELF-LUBRICATING**

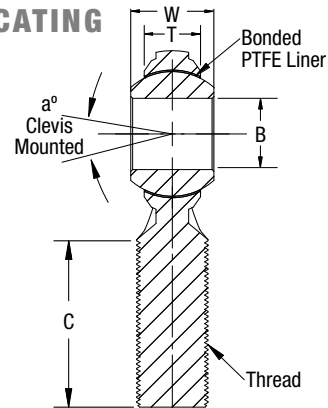

This series is designed as an economical, high load rod end bearing. It features a heat treated alloy steel body and an optional self-lubricating PTFE liner (PCM-T).

# PCYM-T & PCYF-T Alloy Steel

PTFE Lined - Right & Left Hand Threads - Male & Female

**H I G H M I S A L I G N M E N T**

**Inch  
2-Piece  
Rod Ends**

**QA1**

## PCYM-T & PCYF-T

### Features

#### BALL

- 52100 Bearing Steel
- Heat Treated
- High Misalignment

- Hard Chrome Plated
- Precision Ground

#### BODY

- Alloy Steel
- PTFE Lined

- Heat Treated
- Black Oxide Coated

#### PART NUMBER

#### DIMENSIONS IN INCHES

### PCYM-T Male

Right Hand	Left Hand	B + .0015 - .0005	W ± .005	A ± .015	D Ref.	C + .062 - .031	Thread UNF-3A	Misalign. Angle a°	Ult. Radial Static Load Lbs.	Approx. Brg. Wgt. Lbs.
PCYMR6T	PCYML6T	0.3750	0.875	2.125	1.125	1.375	3/8-24	55	11,050	0.14
PCYMR7T	PCYML7T	0.4375	1.000	2.438	1.312	1.500	7/16-20	58	14,449	0.22
PCYMR8T	PCYML8T	0.5000	1.250	2.625	1.500	1.625	1/2-20	65	16,240	0.33
PCYMR8-10T	PCYML8-10T	0.5000	1.250	2.875	1.750	1.750	5/8-18	65	24,158	0.44
PCYMR10T	PCYML10T	0.6250	1.375	2.875	1.750	1.750	5/8-18	64	21,219	0.51
PCYMR10-12T	PCYML10-12T	0.6250	1.375	3.375	2.000	2.000	3/4-16	64	30,290	0.68
PCYMR12T	PCYML12T	0.7500	1.500	3.375	2.000	2.000	3/4-16	61	29,127	0.79

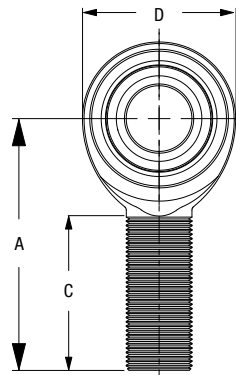

### SELF-LUBRICATING

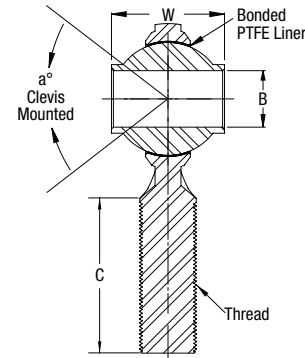

#### PART NUMBER

#### DIMENSIONS IN INCHES

### PCYF-T Female

Right Hand	Left Hand	B + .0015 - .0005	W ± .005	A ± .015	D Ref.	C + .062 - .031	E ± .010	F + .002 - .010	Thread UNF-2B	Misalign. Angle a°	Ult. Radial Static Load Lbs.	Approx. Brg. Wgt. Lbs.
PCYFR6T	PCYFL6T	0.375	0.875	2.125	1.125	1.062	0.687	0.562	3/8-24	55	11,050	0.20
PCYFR8T	PCYFL8T	0.500	1.250	2.625	1.500	1.375	0.875	0.750	1/2-20	65	16,240	0.43
PCYFR10T	PCYFL10T	0.625	1.375	2.875	1.750	1.562	1.000	0.875	5/8-18	64	21,219	0.57
PCYFR12T	PCYFL12T	0.750	1.500	3.375	2.000	1.785	1.125	1.000	3/4-16	61	29,127	0.84

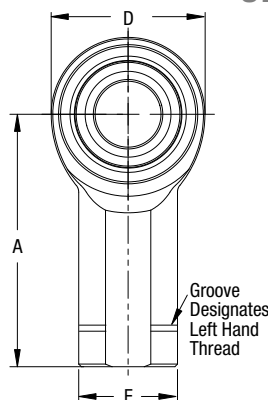

### SELF-LUBRICATING

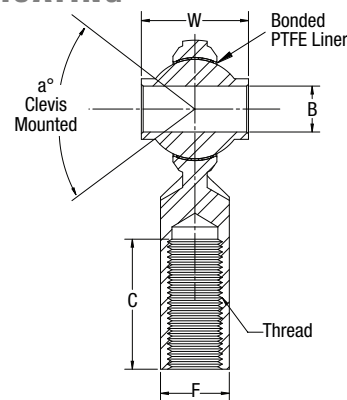

This series, unique to QA1, offers economical, high load, high misalignment rod end bearings. These bearings feature a self-lubricating PTFE liner, a high misalignment ball and a heat treated alloy steel body.



### HM & HF Features

**BALL**

- 52100 Bearing Steel
- Heat Treated
- Hard Chrome Plated
- Precision Ground

**RACE**

- Alloy Steel

**BODY**

- Alloy Steel
- Heat Treated
- Protective Coated for Corrosion Resistance

PART NUMBER

DIMENSIONS IN INCHES

### HM Male

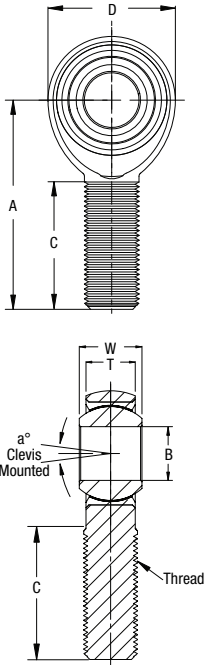

Right Hand	Left Hand	B + .0015 - .0005	W + .000 - .005	T ± .005	A ± .015	D ± .010	Ball Dia. Ref.	C + .062 - .031	Thread UNF-3A	Misalign. Angle a°	Ult. Static Load Lbs.	Approx. Brg. Wgt. Lbs.
HMR3	HML3	0.1900	0.312	0.250	1.250	0.625	0.437	0.750	10-32	13	2,851	0.03
HMR3-4	HML3-4	0.1900	0.312	0.250	1.562	0.750	0.437	1.000	1/4-28	10	5,260	0.04
HMR4	HML4	0.2500	0.375	0.281	1.562	0.750	0.500	1.000	1/4-28	16	5,260	0.04
HMR5	HML5	0.3125	0.437	0.344	1.875	0.875	0.625	1.250	5/16-24	14	7,639	0.07
HMR6	HML6	0.3750	0.500	0.406	1.938	1.000	0.719	1.250	3/8-24	12	9,544	0.11
HMR6-7	HML6-7	0.3750	0.500	0.406	2.125	1.125	0.719	1.375	7/16-20	10	17,508	0.16
HMR7	HML7	0.4375	0.562	0.437	2.125	1.125	0.812	1.375	7/16-20	14	10,285	0.16
HMR7-8	HML7-8	0.4375	0.562	0.437	2.438	1.312	0.812	1.500	1/2-20	12	23,452	0.25
HMR8	HML8	0.5000	0.625	0.500	2.438	1.312	0.937	1.500	1/2-20	12	16,238	0.25
HMR8H	HML8H	0.5000	0.625	0.500	2.625	1.500	0.937	1.625	1/2-20	12	31,390	0.34
HMR8-10	HML8-10	0.5000	0.625	0.500	2.625	1.500	0.937	1.625	5/8-18	10	31,390	0.38
HMR10	HML10	0.6250	0.750	0.562	2.625	1.500	1.125	1.625	5/8-18	16	17,995	0.38
HMR10-12	HML10-12	0.6250	0.750	0.562	2.875	1.750	1.125	1.750	3/4-16	13	40,572	0.60
HMR12	HML12	0.7500	0.875	0.687	2.875	1.750	1.312	1.750	3/4-16	14	28,081	0.60
HMR14	HML14	0.8750	0.875	0.765	3.375	2.000	1.375	2.000	7/8-14	7	45,051	0.90
HMR16	HML16	1.0000	1.375	1.000	4.125	2.750	1.875	2.125	1 1/4-12	17	76,200	2.41
HMR16-1	HML16-1	1.0000	1.375	1.000	4.125	2.750	1.875	2.125	1-14*	17	76,200	2.13
HMR16-2	HML16-2	1.0000	1.375	1.000	4.125	2.750	1.875	2.125	1-12	17	76,200	2.13

PART NUMBER

DIMENSIONS IN INCHES

### HF Female

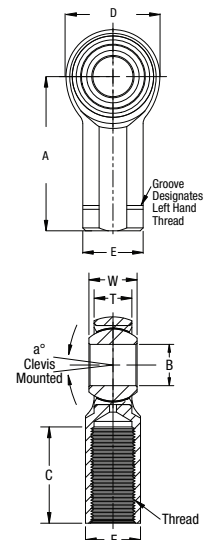

Right Hand	Left Hand	B + .0015 - .0005	W + .000 - .005	T ± .005	A ± .015	D ± .010	E ± .010	F ± .010	Ball Dia. Ref.	C + .062 - .031	Thread UNF-2B	Misalign. Angle a°	Ult. Static Load Lbs.	Approx. Brg. Wgt. Lbs.
HFR3	HFL3	0.1900	0.312	0.250	1.062	0.625	0.406	0.312	0.437	0.562	10-32	13	3,327	0.04
HFR4	HFL4	0.2500	0.375	0.281	1.312	0.750	0.469	0.375	0.500	0.750	1/4-28	16	6,190	0.06
HFR5	HFL5	0.3125	0.437	0.344	1.375	0.875	0.500	0.437	0.625	0.750	5/16-24	14	7,639	0.09
HFR6	HFL6	0.3750	0.500	0.406	1.625	1.000	0.687	0.562	0.719	0.937	3/8-24	12	9,544	0.15
HFR7	HFL7	0.4375	0.562	0.437	1.812	1.125	0.750	0.625	0.812	1.062	7/16-20	14	10,285	0.20
HFR8	HFL8	0.5000	0.625	0.500	2.125	1.312	0.875	0.750	0.937	1.187	1/2-20	12	15,336	0.33
HFR10	HFL10	0.6250	0.750	0.562	2.500	1.500	1.000	0.875	1.125	1.500	5/8-18	16	17,995	0.48
HFR12	HFL12	0.7500	0.875	0.687	2.875	1.750	1.125	1.000	1.312	1.750	3/4-16	14	28,081	0.72
HFR14	HFL14	0.8750	0.875	0.765	3.375	2.000	1.300	1.125	1.375	1.875	7/8-14	7	45,051	1.03
HFR16	HFL16	1.0000	1.375	1.000	4.125	2.750	1.625	1.500	1.875	2.125	1 1/4-12	17	76,200	2.28
HFR16-1	HFL16-1	1.0000	1.375	1.000	4.125	2.750	1.625	1.500	1.875	2.125	1-14*	17	76,200	2.58
HFR16-2	HFL16-2	1.0000	1.375	1.000	4.125	2.750	1.625	1.500	1.875	2.125	1-12	17	76,200	2.58

# HM-T & HF-T Alloy Steel

**Stainless Steel Race - PTFE Lined - Right & Left Hand Threads - Male & Female**

**P R E C I S I O N**

**Inch  
3-Piece  
Rod Ends**

**QA1**

## HM-T & HF-T

### Features

#### BALL

- 52100 Bearing Steel
- Heat Treated
- Hard Chrome Plated
- Precision Ground

#### RACE

- Stainless Steel
- PTFE Lined

#### BODY

- Alloy Steel
- Heat Treated
- Protective Coated for Corrosion Resistance

#### PART NUMBER

#### DIMENSIONS IN INCHES

### HM-T Male

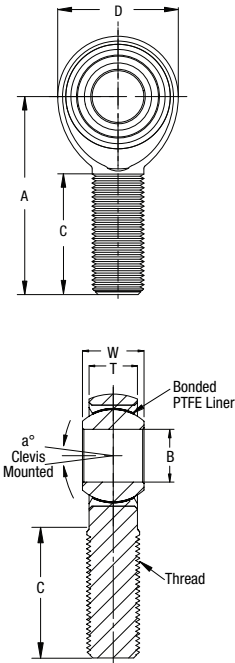

Right Hand	Left Hand	B + .0015 - .0005	W + .000 - .005	T ± .005	A ± .015	D ± .010	Ball Dia. Ref.	C + .062 - .031	Thread UNF-3A	Misalign. Angle a°	Ult. Static Load Lbs.	Radial Load Lbs.	Approx. Brg. Wgt. Lbs.
HMR3T	HML3T	0.1900	0.312	0.250	1.250	0.625	0.437	0.750	10-32	13	2,851	0.03	
HMR3-4T	-	0.1900	0.312	0.250	1.562	0.750	0.437	1.000	1/4-28	10	5,260	0.04	
HMR4T	HML4T	0.2500	0.375	0.281	1.562	0.750	0.500	1.000	1/4-28	16	5,260	0.04	
HMR4-5T	HML4-5T	0.2500	0.375	0.281	1.875	0.875	0.500	1.250	5/16-24	13	8,452	0.07	
HMR5T	HML5T	0.3125	0.437	0.344	1.875	0.875	0.625	1.250	5/16-24	14	7,639	0.07	
HMR5-6T	HML5-6T	0.3125	0.437	0.344	1.938	1.000	0.625	1.250	3/8-24	12	12,978	0.11	
HMR6T	HML6T	0.3750	0.500	0.406	1.938	1.000	0.719	1.250	3/8-24	12	9,544	0.11	
HMR6-7T	HML6-7T	0.3750	0.500	0.406	2.125	1.125	0.719	1.375	7/16-20	10	17,508	0.16	
HMR7T	HML7T	0.4375	0.562	0.437	2.125	1.125	0.812	1.375	7/16-20	14	10,285	0.16	
HMR7-8T	HML7-8T	0.4375	0.562	0.437	2.438	1.312	0.812	1.500	1/2-20	12	23,452	0.25	
HMR8T	HML8T	0.5000	0.625	0.500	2.438	1.312	0.937	1.500	1/2-20	12	16,238	0.25	
HMR8HT	HML8HT	0.5000	0.625	0.500	2.625	1.500	0.937	1.625	1/2-20	12	31,390	0.34	
HMR8-10T	HML8-10T	0.5000	0.625	0.500	2.625	1.500	0.937	1.625	5/8-18	10	31,390	0.38	
HMR10T	HML10T	0.6250	0.750	0.562	2.625	1.500	1.125	1.625	5/8-18	16	17,995	0.38	
HMR10-12T	HML10-12T	0.6250	0.750	0.562	2.875	1.750	1.125	1.750	3/4-16	13	40,572	0.60	
HMR12T	HML12T	0.7500	0.875	0.687	2.875	1.750	1.312	1.750	3/4-16	14	28,081	0.60	
HMR12HT	HML12HT	0.7500	0.875	0.687	3.375	2.000	1.312	1.875	3/4-16	12	55,692	0.92	
HMR12-14T	-	0.7500	0.875	0.687	3.375	2.000	1.312	1.875	7/8-14	12	55,692	0.92	
HMR14T	HML14T	0.8750	0.875	0.765	3.375	2.000	1.375	2.000	7/8-14	7	45,051	0.90	
HMR16T	HML16T	1.0000	1.375	1.000	4.125	2.750	1.875	2.125	1 1/4-12	17	76,200	2.41	
HMR16T-1	HML16T-1	1.0000	1.375	1.000	4.125	2.750	1.875	2.125	1-14*	17	76,200	2.13	
HMR16T-2	-	1.0000	1.375	1.000	4.125	2.750	1.875	2.125	1-12	17	76,200	2.13	

### SELF-LUBRICATING

#### PART NUMBER

#### DIMENSIONS IN INCHES

### HF-T Female

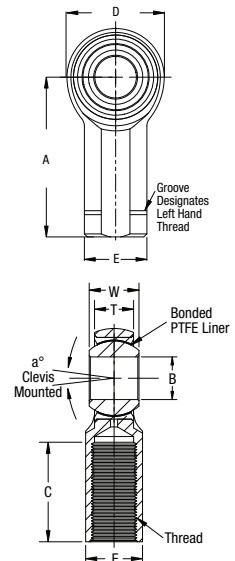

Right Hand	Left Hand	B + .0015 - .0005	W + .000 - .005	T ± .005	A ± .015	D ± .010	E ± .010	F ± .010	Ball Dia. Ref.	C + .062 - .031	Thread UNF-2B	Misalign. Angle a°	Ult. Static Load Lbs.	Radial Load Lbs.	Approx. Brg. Wgt. Lbs.
HFR3T	HFL3T	0.1900	0.312	0.250	1.062	0.625	0.406	0.312	0.437	0.562	10-32	13	3,327	0.04	
HFR4T	HFL4T	0.2500	0.375	0.281	1.312	0.750	0.469	0.375	0.500	0.750	1/4-28	16	6,190	0.06	
HFR5T	HFL5T	0.3125	0.437	0.344	1.375	0.875	0.500	0.437	0.625	0.750	5/16-24	14	7,639	0.09	
HFR6T	HFL6T	0.3750	0.500	0.406	1.625	1.000	0.687	0.562	0.719	0.937	3/8-24	12	9,544	0.15	
HFR7T	HFL7T	0.4375	0.562	0.437	1.812	1.125	0.750	0.625	0.812	1.062	7/16-20	14	10,285	0.20	
HFR8T	HFL8T	0.5000	0.625	0.500	2.125	1.312	0.875	0.750	0.937	1.187	1/2-20	12	15,336	0.33	
HFR10T	HFL10T	0.6250	0.750	0.562	2.500	1.500	1.000	0.875	1.125	1.500	5/8-18	16	17,955	0.48	
HFR12T	HFL12T	0.7500	0.875	0.687	2.875	1.750	1.125	1.000	1.312	1.750	3/4-16	14	28,081	0.72	
HFR14T	-	0.8750	0.875	0.765	3.375	2.000	1.300	1.125	1.375	1.875	7/8-14	7	45,051	1.03	
HFR16T	HFL16T	1.0000	1.375	1.000	4.125	2.750	1.625	1.500	1.875	2.125	1 1/4-12	17	76,200	2.58	

### SELF-LUBRICATING

### KM & KF Features

**BALL**

- 52100 Bearing Steel
- Heat Treated
- Hard Chrome Plated
- Precision Ground

**RACE**

- Alloy Steel
- Heat Treated

**BODY**

- Carbon Steel (Alloy Steel - Mfr.'s Option)
- Protective Coated for Corrosion Resistance

**PART NUMBER**

**DIMENSIONS IN INCHES**

### KM Male

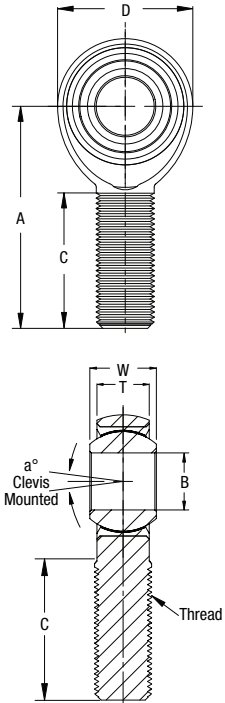

Right Hand	Left Hand	B + .0015 - .0005	W + .000 - .005	T ± .005	A ± .015	D ± .010	Ball Dia. Ref.	C + .062 - .031	Thread UNF-3A	Misalign. Angle a°	Ult. Radial Static Load Lbs.	Approx. Brg. Wgt. Lbs.
KMR3	KML3	0.1900	0.312	0.250	1.250	0.625	0.437	0.750	10-32	13	1,169	0.03
KMR3-4	KML3-4	0.1900	0.312	0.250	1.562	0.750	0.437	1.000	1/4-28	10	2,158	0.04
KMR4	KML4	0.2500	0.375	0.281	1.562	0.750	0.500	1.000	1/4-28	16	2,158	0.04
KMR4-5	KML4-5	0.2500	0.375	0.281	1.875	0.875	0.500	1.250	5/16-24	13	3,467	0.07
KMR5	KML5	0.3125	0.437	0.344	1.875	0.875	0.625	1.250	5/16-24	14	2,784	0.07
KMR6	KML6	0.3750	0.500	0.406	1.938	1.000	0.719	1.250	3/8-24	12	3,915	0.11
KMR6-7	KML6-7	0.3750	0.500	0.406	2.125	1.125	0.719	1.375	7/16-20	10	7,180	0.16
KMR7	KML7	0.4375	0.562	0.437	2.125	1.125	0.812	1.375	7/16-20	14	4,218	0.16
KMR7-8	KML7-8	0.4375	0.562	0.437	2.438	1.312	0.812	1.500	1/2-20	12	9,620	0.24
KMR8	KML8	0.5000	0.625	0.500	2.438	1.312	0.937	1.500	1/2-20	12	6,660	0.25
KMR8-10	KML8-10	0.5000	0.625	0.500	2.625	1.500	0.937	1.625	5/8-18	10	12,807	0.37
KMR10	KML10	0.6250	0.750	0.562	2.625	1.500	1.125	1.625	5/8-18	16	7,364	0.38
KMR10-12	KML10-12	0.6250	0.750	0.562	2.875	1.750	1.125	1.750	3/4-16	13	16,565	0.57
KMR12	KML12	0.7500	0.875	0.687	2.875	1.750	1.312	1.750	3/4-16	14	11,518	0.60
KMR12-14	KML12-14	0.7500	0.875	0.687	3.375	2.000	1.312	1.875	7/8-14	12	22,843	0.92
KMR14	KML14	0.8750	0.875	0.765	3.375	2.000	1.375	2.000	7/8-14	7	18,476	0.92
KMR16	KML16	1.0000	1.375	1.000	4.125	2.750	1.875	2.125	1 1/4-12	17	43,541	2.41
KMR16-1	KML16-1	1.0000	1.375	1.000	4.125	2.750	1.875	2.125	1-14*	17	43,541	2.13
KMR16-2	KML16-2	1.0000	1.375	1.000	4.125	2.750	1.875	2.125	1-12	17	43,541	2.13

**PART NUMBER**

**DIMENSIONS IN INCHES**

### KF Female

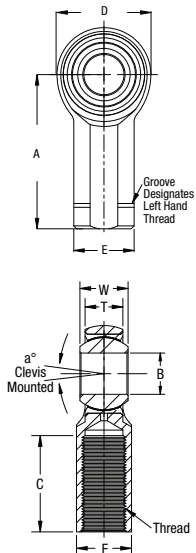

Right Hand	Left Hand	B + .0015 - .0005	W + .000 - .005	T ± .005	A ± .015	D ± .010	E ± .010	F ± .010	Ball Dia. Ref.	C + .062 - .031	Thread UNF-2B	Misalign. Angle a°	Ult. Radial Static Load Lbs.	Approx. Brg. Wgt. Lbs.
KFR3	KFL3	0.1900	0.312	0.250	1.062	0.625	0.406	0.312	0.437	0.562	10-32	13	1,531	0.04
KFR4	KFL4	0.2500	0.375	0.281	1.312	0.750	0.469	0.375	0.500	0.750	1/4-28	16	2,539	0.06
KFR5	KFL5	0.3125	0.437	0.344	1.375	0.875	0.500	0.437	0.625	0.750	5/16-24	14	3,133	0.09
KFR6	KFL6	0.3750	0.500	0.406	1.625	1.000	0.687	0.562	0.719	0.937	3/8-24	12	3,915	0.15
KFR7	KFL7	0.4375	0.562	0.437	1.812	1.125	0.750	0.625	0.812	1.062	7/16-20	14	4,218	0.20
KFR8	KFL8	0.5000	0.625	0.500	2.125	1.312	0.875	0.750	0.937	1.187	1/2-20	12	6,660	0.33
KFR10	KFL10	0.6250	0.750	0.562	2.500	1.500	1.000	0.875	1.125	1.500	5/8-18	16	7,364	0.48
KFR12	KFL12	0.7500	0.875	0.687	2.875	1.750	1.125	1.000	1.312	1.750	3/4-16	14	11,518	0.72
KFR14	KFL14	0.8750	0.875	0.765	3.375	2.000	1.300	1.125	1.375	1.875	7/8-14	7	18,476	1.03
KFR16	KFL16	1.0000	1.375	1.000	4.125	2.750	1.625	1.500	1.875	2.125	1 1/4-12	17	40,889	2.28
KFR16-1	KFL16-1	1.0000	1.375	1.000	4.125	2.750	1.625	1.500	1.875	2.125	1-14*	17	43,541	2.58
KFR16-2	KFL16-2	1.0000	1.375	1.000	4.125	2.750	1.625	1.500	1.875	2.125	1-12	17	43,541	2.58

Load ratings apply only to rod ends without grease fittings. For ratings with grease fittings, please contact us.

# KM-T & KF-T Carbon Steel

Stainless Steel Race - PTFE Lined - Right & Left Hand Threads  
- Male & Female

P R E C I S I O N

Inch  
3-Piece  
Rod Ends

QA1

## KM-T & KF-T

### Features

#### BALL

- 52100 Bearing Steel
- Heat Treated
- Hard Chrome Plated
- Precision Ground

#### RACE

- Stainless Steel
- PTFE Lined

#### BODY

- Carbon Steel (Alloy Steel - Mfr.'s Option)
- Protective Coated for Corrosion Resistance

#### PART NUMBER

#### DIMENSIONS IN INCHES

### KM-T Male

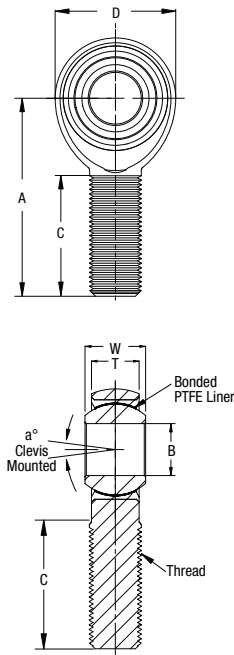

Right Hand	Left Hand	B + .0015 - .0005	W + .000 - .005	T ± .005	A ± .015	D ± .010	Ball Dia. Ref.	C + .062 - .031	Thread UNF-3A	Misalign. Angle a°	Ult. Static Load Lbs.	Radial Static Load Lbs.	Approx. Brg. Wgt. Lbs.
KMR3T	KML3T	0.1900	0.312	0.250	1.250	0.625	0.437	0.750	10-32	13	1,169	0.03	
KMR3-4T	-	0.1900	0.312	0.250	1.562	0.750	0.437	1.000	1/4-28	10	2,158	0.04	
KMR4T	KML4T	0.2500	0.375	0.281	1.562	0.750	0.500	1.000	1/4-28	16	2,158	0.04	
KMR4-5T	KML4-5T	0.2500	0.375	0.281	1.875	0.875	0.500	1.250	5/16-24	13	3,467	0.07	
KMR5T	KML5T	0.3125	0.437	0.344	1.875	0.875	0.625	1.250	5/16-24	14	2,784	0.07	
KMR5-6T	KML5-6T	0.3125	0.437	0.344	1.938	1.000	0.625	1.250	3/8-24	12	5,323	0.11	
KMR6T	KML6T	0.3750	0.500	0.406	1.938	1.000	0.719	1.250	3/8-24	12	3,915	0.11	
KMR6-7T	KML6-7T	0.3750	0.500	0.406	2.125	1.125	0.719	1.375	7/16-20	10	7,180	0.16	
KMR7T	KML7T	0.4375	0.562	0.437	2.125	1.125	0.812	1.375	7/16-20	14	4,218	0.16	
KMR7-8T	KML7-8T	0.4375	0.562	0.437	2.438	1.312	0.812	1.500	1/2-20	12	9,620	0.24	
KMR8T	KML8T	0.5000	0.625	0.500	2.438	1.312	0.937	1.500	1/2-20	12	6,660	0.25	
KMR8-10T	KML8-10T	0.5000	0.625	0.500	2.625	1.500	0.937	1.625	5/8-18	10	12,807	0.37	
KMR10T	KML10T	0.6250	0.750	0.562	2.625	1.500	1.125	1.625	5/8-18	16	7,364	0.38	
KMR10-12T	KML10-12T	0.6250	0.750	0.562	2.875	1.750	1.125	1.750	3/4-16	13	16,565	0.57	
KMR12T	KML12T	0.7500	0.875	0.687	2.875	1.750	1.312	1.750	3/4-16	14	11,518	0.60	
KMR12-14T	KML12-14T	0.7500	0.875	0.687	3.375	2.000	1.312	1.875	7/8-14	12	22,843	0.92	
KMR14T	KML14T	0.8750	0.875	0.765	3.375	2.000	1.375	2.000	7/8-14	7	18,476	0.92	
KMR16T	KML16T	1.0000	1.375	1.000	4.125	2.750	1.875	2.125	1 1/4-12	17	43,541	2.41	
KMR16T-1	KML16T-1	1.0000	1.375	1.000	4.125	2.750	1.875	2.125	1-14*	17	43,541	2.13	
KMR16T-2	-	1.0000	1.375	1.000	4.125	2.750	1.875	2.125	1-12	17	43,451	2.13	

### SELF-LUBRICATING

#### PART NUMBER

#### DIMENSIONS IN INCHES

### KF-T Female

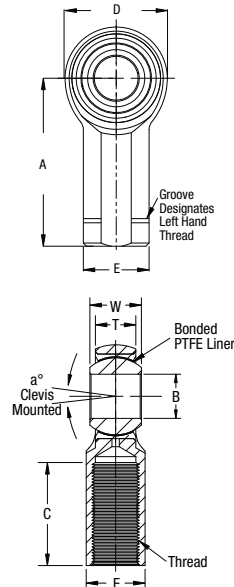

Right Hand	Left Hand	B + .0015 - .0005	W + .000 - .005	T ± .005	A ± .015	D ± .010	E ± .010	F ± .010	Ball Dia. Ref.	C + .062 - .031	Thread UNF-2B	Misalign. Angle a°	Ult. Static Load Lbs.	Radial Static Load Lbs.	Approx. Brg. Wgt. Lbs.
KFR3T	KFL3T	0.1900	0.312	0.250	1.062	0.625	0.406	0.312	0.437	0.562	10-32	13	1,531	0.04	
KFR4T	KFL4T	0.2500	0.375	0.281	1.312	0.750	0.469	0.375	0.500	0.750	1/4-28	16	2,539	0.06	
KFR5T	KFL5T	0.3125	0.437	0.344	1.375	0.875	0.500	0.437	0.625	0.750	5/16-24	14	3,133	0.09	
KFR6T	KFL6T	0.3750	0.500	0.406	1.625	1.000	0.687	0.562	0.719	0.937	3/8-24	12	3,915	0.15	
KFR7T	KFL7T	0.4375	0.562	0.437	1.812	1.125	0.750	0.625	0.812	1.062	7/16-20	14	4,218	0.20	
KFR8T	KFL8T	0.5000	0.625	0.500	2.125	1.312	0.875	0.750	0.937	1.187	1/2-20	12	6,660	0.33	
KFR10T	KFL10T	0.6250	0.750	0.562	2.500	1.500	1.000	0.875	1.125	1.500	5/8-18	16	7,364	0.48	
KFR12T	KFL12T	0.7500	0.875	0.687	2.875	1.750	1.125	1.000	1.312	1.750	3/4-16	14	11,518	0.72	
KFR14T	-	0.8750	0.875	0.765	3.375	2.000	1.300	1.125	1.375	1.875	7/8-14	7	18,476	1.03	
KFR16T	KFL16T	1.0000	1.375	1.000	4.125	2.750	1.625	1.500	1.875	2.125	1 1/4-12	17	40,889	2.28	

### SELF-LUBRICATING

Load ratings apply only to rod ends without grease fittings.

### KM & KF Large Bore

#### Features

#### BALL

- 52100 Bearing Steel
- Heat Treated
- MOS<sup>2</sup> Coated

#### RACE

- 52100 Bearing Steel
- Heat Treated
- MOS<sup>2</sup> Coated
- Sealed

#### BODY

- Alloy Steel
- Protective Coated for Corrosion Resistance
- Grease Fitting Installed as Standard

#### PART NUMBER

#### DIMENSIONS IN INCHES

#### KM Male

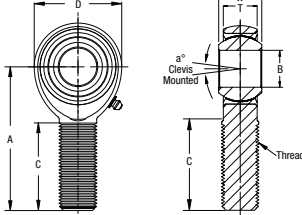

Right Hand	Left Hand	B + .0000 - .0005	W + .000 - .005	T ± .020	A ± .040	D ± .030	Ball Dia. Ref.	C + .062 - .031	Thread UNF-3A	Misalign. Angle a°	Ult. Radial Static Load Lbs.	Approx. Brg. Wgt. Lbs.
KMR20Z	KML20Z	1.250	1.093	0.937	4.125	2.750	1.795	2.125	1 1/4-12	7.0	44,500	2.41
KMR24Z	KML24Z	1.500	1.312	1.125	5.375	3.500	2.155	3.000	1 1/2-12	6.5	64,770	4.75
KMR32Z	KML32Z	2.000	1.750	1.500	8.000	5.000	2.875	4.500	2-12*	6.0	153,528	14.25

#### PART NUMBER

#### DIMENSIONS IN INCHES

#### KF Female

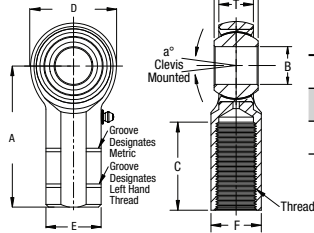

Right Hand	Left Hand	B + .0000 - .0005	W + .000 - .005	T ± .020	A ± .040	D ± .030	E ± .045	F ± .030	K ± .030	Ball Dia. Ref.	C + .062 - .031	Thread UNF-2B	Misalign. Angle a°	Ult. Radial Static Load Lbs.	Approx. Brg. Wgt. Lbs.
KFR20Z	KFL20Z	1.250	1.093	0.937	4.125	2.750	1.625	1.500	0.500	1.795	2.125	1 1/4-12	7.0	44,500	2.13
KFR24Z	KFL24Z	1.500	1.312	1.125	5.375	3.500	2.250	2.000	0.875	2.155	2.625	1 1/2-12	6.5	64,770	6.50
KFR32Z	KFL32Z	2.000	1.750	1.500	8.000	5.000	3.125	2.750	2.062	2.875	4.000	2-12*	6.0	153,528	15.00

### VM & VF

#### Features

#### BALL

- 52100 Bearing Steel
- Heat Treated
- Hard Chrome Plated
- Precision Ground

#### RACE

- Sintered Bronze
- Oil Impregnated

#### BODY

- Carbon Steel
- Protective Coated for Corrosion Resistance

#### PART NUMBER

#### DIMENSIONS IN INCHES

#### VM Male

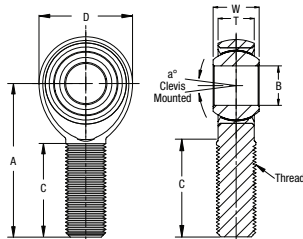

Right Hand	Left Hand	B + .0025 - .0005	W ± .005	T ± .005	A ± .015	D ± .010	Ball Dia. Ref.	C + .062 - .031	Thread UNF-3A	Misalign. Angle a°	Ult. Radial Static Load Lbs.	Approx. Brg. Wgt. Lbs.
VMR3	VML3	0.1900	0.312	0.250	1.250	0.625	0.437	0.750	10-32	13	1,169	0.03
VMR4	VML4	0.2500	0.375	0.281	1.562	0.750	0.500	1.000	1/4-28	16	2,158	0.04
VMR5	VML5	0.3125	0.437	0.344	1.875	0.875	0.625	1.250	5/16-24	12	2,784	0.07
VMR6	VML6	0.3750	0.500	0.406	1.938	1.000	0.719	1.250	3/8-24	12	3,915	0.11
VMR7	VML7	0.4375	0.562	0.437	2.125	1.125	0.812	1.375	7/16-20	14	4,218	0.16
VMR8	VML8	0.5000	0.625	0.500	2.438	1.312	0.937	1.500	1/2-20	12	6,660	0.25
VMR10	VML10	0.6250	0.750	0.562	2.625	1.500	1.125	1.625	5/8-18	16	7,364	0.38
VMR12	VML12	0.7500	0.875	0.687	2.875	1.750	1.312	1.750	3/4-16	14	11,518	0.60

### SELF-LUBRICATING

#### PART NUMBER

#### DIMENSIONS IN INCHES

#### VF Female

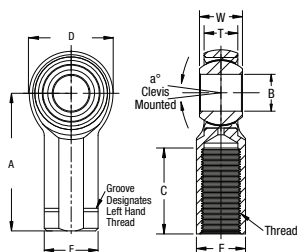

Right Hand	Left Hand	B + .0025 - .0005	W ± .005	T ± .005	A ± .015	D ± .010	E ± .010	F ± .010	Ball Dia. Ref.	C + .062 - .031	Thread UNF-2B	Misalign. Angle a°	Ult. Radial Static Load Lbs.	Approx. Brg. Wgt. Lbs.
VFR3	VFL3	0.1900	0.312	0.250	1.062	0.625	0.406	0.312	0.562	0.562	10-32	13	1,531	0.04
VFR4	VFL4	0.2500	0.375	0.281	1.312	0.750	0.469	0.375	0.750	0.750	1/4-28	16	2,539	0.06
VFR5	VFL5	0.3125	0.437	0.344	1.375	0.875	0.500	0.437	0.750	0.750	5/16-24	12	3,133	0.09
VFR6	VFL6	0.3750	0.500	0.406	1.625	1.000	0.687	0.562	0.937	0.937	3/8-24	12	3,915	0.15
VFR7	VFL7	0.4375	0.562	0.437	1.812	1.125	0.750	0.625	1.062	1.062	7/16-20	14	4,218	0.20
VFR8	VFL8	0.5000	0.625	0.500	2.125	1.312	0.875	0.750	1.189	1.187	1/2-20	12	6,660	0.33
VFR10	VFL10	0.6250	0.750	0.562	2.500	1.500	1.000	0.875	1.125	1.500	5/8-18	16	7,364	0.48
VFR12	VFL12	0.7500	0.875	0.687	2.875	1.750	1.125	1.000	1.312	1.750	3/4-16	14	11,518	0.72

Load ratings apply only to rod ends without grease fittings.

### SELF-LUBRICATING

For ratings with grease fittings, please contact us.

# NM & NF Carbon Steel

Nylon Self-Lubricating Race - Right & Left Hand  
Threads - Male & Female

**C O M M E R C I A L**

**Inch  
Injected Molded  
Rod Ends**

**QA1**

## NM & NF Features

### BALL

- 52100 Bearing Steel
- Heat Treated
- Hard Chrome Plated
- Precision Ground

### RACE

- Reinforced Nylon 12 with PTFE

### BODY

- Carbon Steel
- Protective Coated for Corrosion Resistance

## NM Male

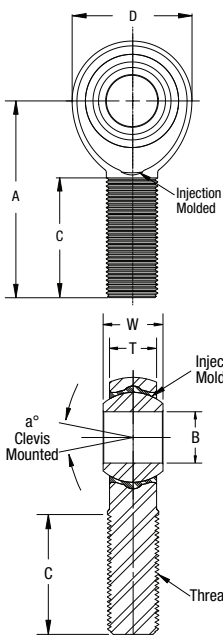

### PART NUMBER

### DIMENSIONS IN INCHES

Right Hand	Left Hand	B + .0025 - .0005	W ± .005	T ± .005	A ± .015	D ± .010	Ball Dia. Ref.	C + .062 - .031	Thread UNF-3A	Misalign. Angle a°	Ult. Radial Static Load Lbs.	Approx. Brg. Wgt. Lbs.
NMR3	NML3	0.1900	0.312	0.250	1.250	0.625	0.437	0.750	10-32	13	1,210	0.02
NMR4	NML4	0.2500	0.375	0.281	1.562	0.750	0.500	1.000	1/4-28	16	2,470	0.04
NMR5	NML5	0.3125	0.437	0.344	1.875	0.875	0.625	1.250	5/16-24	14	2,740	0.07
NMR6	NML6	0.3750	0.500	0.406	1.938	1.000	0.719	1.250	3/8-24	12	4,210	0.11
NMR7	NML7	0.4375	0.562	0.437	2.125	1.125	0.812	1.375	7/16-20	14	5,350	0.15
NMR8	NML8	0.5000	0.625	0.500	2.438	1.312	0.937	1.500	1/2-20	12	6,430	0.23
NMR10	NML10	0.6250	0.750	0.562	2.625	1.500	1.125	1.625	5/8-18	16	8,300	0.36
NMR12	NML12	0.7500	0.875	0.687	2.875	1.750	1.312	1.750	3/4-16	14	10,900	0.57

## SELF-LUBRICATING

This series features a molded race compound designed to provide low friction, low moisture absorbing properties and high wear resistance. QA1's design is unique in the industry since no holes need to be drilled in the rod end body, thereby allowing the rod end to maintain its full strength and integrity.

## NF Female

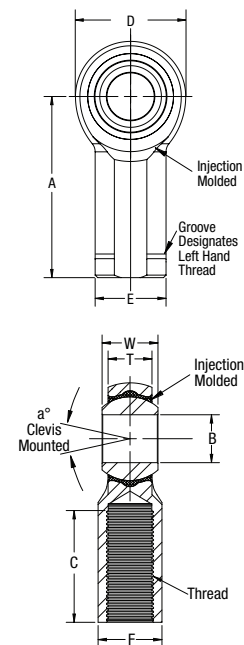

### PART NUMBER

### DIMENSIONS IN INCHES

Right Hand	Left Hand	B + .0025 - .0005	W ± .005	T ± .005	A ± .015	D ± .010	E ± .010	F ± .010	Ball Dia. Ref.	C + .062 - .031	Thread UNF-2B	Misalign. Angle a°	Ult. Radial Static Load Lbs.	Approx. Brg. Wgt. Lbs.
NFR3	NFL3	0.1900	0.312	0.250	1.062	0.625	0.406	0.312	0.437	0.562	10-32	13	1,210	0.04
NFR4	NFL4	0.2500	0.375	0.281	1.312	0.750	0.469	0.375	0.500	0.750	1/4-28	16	2,470	0.06
NFR5	NFL5	0.3125	0.437	0.344	1.375	0.875	0.500	0.437	0.625	0.750	5/16-24	14	2,740	0.08
NFR6	NFL6	0.3750	0.500	0.406	1.625	1.000	0.687	0.562	0.719	0.937	3/8-24	12	4,100	0.14
NFR7	NFL7	0.4375	0.562	0.437	1.812	1.125	0.750	0.625	0.812	1.062	7/16-20	14	5,350	0.19
NFR8	NFL8	0.5000	0.625	0.500	2.125	1.312	0.875	0.750	0.937	1.187	1/2-20	12	6,430	0.31
NFR10	NFL10	0.6250	0.750	0.562	2.500	1.500	1.000	0.875	1.125	1.500	5/8-18	16	8,300	0.45
NFR12	NFL12	0.7500	0.875	0.687	2.875	1.750	1.125	1.000	1.312	1.750	3/4-16	14	10,900	0.67

## SELF-LUBRICATING

### MXM & MXF Features

#### BALL

- 52100 Bearing Steel
- Heat Treated
- Hard Chrome Plated
- Precision Ground

#### RACE

- Reinforced Nylon 12 with PTFE Liner

#### BODY

- Alloy Steel
- Heat Treated
- Protective Coated for Corrosion Resistance

#### EXCLUSIVE FEATURES

- Metal-to-Metal Support for Heavy Shock Loads
- Increased Cross-Sectional Thickness for Greater Tensile Strength

#### PART NUMBER

#### DIMENSIONS IN MILLIMETERS

### MXM Male

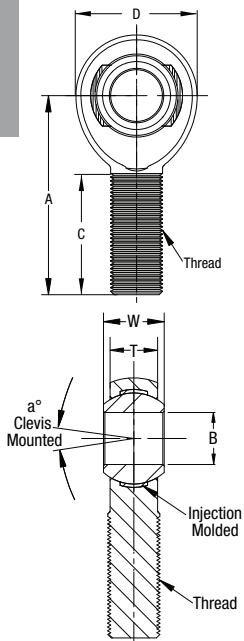

Right Hand	Left Hand	B + .065 - .012	W + .000 - .13	T ± .12	A ± .4	D ± .38	Ball Dia. Ref.	C + 1.5 - .75	Thread 6g	Misalign. Angle a°	Ult. Radial Static Load (Newtons)	Approx. Brg. Wgt. (Grams)
MXMR6	MXML6	6	9	7.00	36	19.00	12.70	22	M6X1.0	13	18,186	19
MXMR8	MXML8	8	12	8.75	42	22.25	15.88	25	M8X1.25	18	33,114	33
MXMR10	MXML10	10	14	10.50	48	27.00	19.05	29	M10X1.5	17	52,476	57
MXMR12	MXML12	12	16	12.00	54	30.00	22.23	33	M12X1.75	17	68,147	82
MXMR14	MXML14	14	19	13.50	60	34.75	25.40	36	M14X2.0	21	90,386	125
MXMR16	MXML16	16	21	14.25	66	38.00	28.58	40	M16X2.0	23	97,714	168

### SELF-LUBRICATING

#### PART NUMBER

#### DIMENSIONS IN MILLIMETERS

### MXF Female

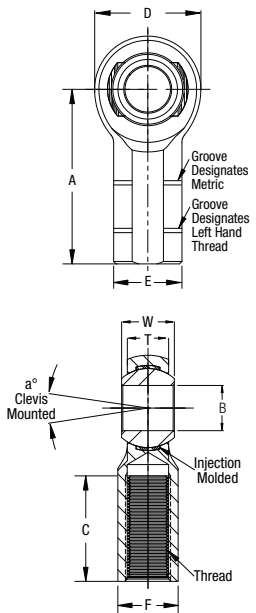

Right Hand	Left Hand	B + .065 - .012	W + .000 - .13	T ± .12	A ± .4	D ± .38	E ± .25	F ± .25	Ball Dia. Ref.	C + 1.5 - .75	Thread 6H	Misalign. Angle a°	Ult. Radial Static Load (Newtons)	Approx. Brg. Wgt. (Grams)
MXFR6	MXFL6	6	9	7.00	30	19.00	13	11	12.70	14	M6X1.0	13	34,399	29
MXFR8	MXFL8	8	12	8.75	36	22.25	16	14	15.88	17	M8X1.25	18	41,710	51
MXFR10	MXFL10	10	14	10.50	43	27.00	19	17	19.05	21	M10X1.5	17	63,442	86
MXFR12	MFL12	12	16	12.00	50	30.00	22	19	22.23	24	M12X1.75	17	68,147	124
MXFR14	MXFL14	14	19	13.50	57	34.75	25	22	25.40	27	M14X2.0	21	90,386	184
MXFR16	MXFL16	16	21	14.25	64	38.00	27	22	28.58	33	M16X2.0	23	97,714	223

### SELF-LUBRICATING

This design results in metal-to-metal support for heavy shock loads and smooth operation for low loads. MX Series rod ends are appropriate and provide the best performance for most applications. This series is moderately priced.

# MGM-T & MGF-T Stainless Steel

PTFE Lined - Right & Left Hand Threads - Male & Female

**C O M M E R C I A L**

**Metric  
2-Piece  
Rod Ends**

**QA1**

## MGM-T & MGF-T Features

### BALL

- 440C Stainless Steel
- Heat Treated
- Hard Chrome Plated
- Precision Ground

### BODY

- 300 Series Stainless Steel
- PTFE Lined

### PART NUMBER

### DIMENSIONS IN MILLIMETERS

## MGM-T Male

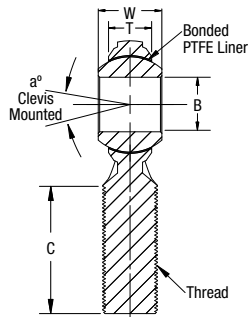
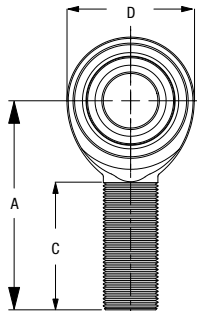

Right Hand	Left Hand	B + .065 - .012	W ± .12	T Ref.	A ± .40	D ± .38	Ball Dia. Ref.	C ± 1.0	Thread 6g	Misalign. Angle a°	Ult. Radial Static Load (Newtons)	Approx. Brg. Wgt. (Grams)
MGMR5T	MGML5T	5	8	5.75	33	16.00	11.10	20	M5X.08	22	4,056	12
MGMR6T	MGML6T	6	9	6.25	36	19.00	12.70	22	M6X1.0	23	6,093	18
MGMR8T	MGML8T	8	12	8.00	42	22.25	15.88	25	M8X1.25	28	9,118	31
MGMR10T	MGML10T	10	14	9.50	48	27.00	19.05	29	M10X1.5	26	14,144	68
MGMR12T	MGML12T	12	16	10.75	54	30.00	22.23	33	M12X1.75	27	17,373	78
MGMR14T	MGML14T	14	19	12.25	60	34.75	25.40	36	M14X2.0	30	23,699	118
MGMR16T	MGML16T	16	21	12.75	66	38.00	28.58	40	M16X2.0	33	25,162	173

**SELF-LUBRICATING**

### PART NUMBER

### DIMENSIONS IN MILLIMETERS

## MGF-T Female

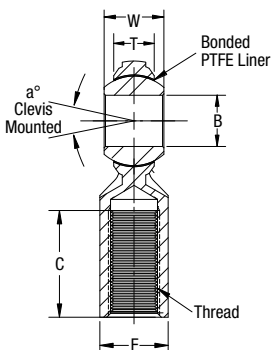
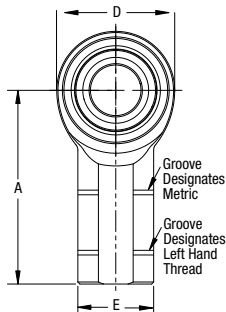

Right Hand	Left Hand	B + .065 - .012	W ± .12	T Ref.	A ± .40	D ± .38	E ± .25	F ± .25	Ball Dia. Ref.	C ± 1.0	Thread 6H	Misalign. Angle a°	Ult. Radial Static Load (Newtons)	Approx. Brg. Wgt. (Grams)
MGFR5T	MGFL5T	5	8	5.75	27	16.00	11	9	11.10	14	M5X.08	22	4,136	18
MGFR6T	MGFL6T	6	9	6.25	30	19.00	13	11	12.70	14	M6X1.0	23	6,138	25
MGFR8T	MGFL8T	8	12	8.00	36	22.25	16	14	15.88	17	M8X1.25	28	9,340	40
MGFR10T	MGFL10T	10	14	9.50	43	27.00	19	17	19.05	21	M10X1.5	26	15,310	80
MGFR12T	MGFL12T	12	16	10.75	50	30.00	22	19	22.23	24	M12X1.75	27	17,373	95
MGFR14T	MGFL14T	14	19	12.25	57	34.75	25	22	25.40	27	M14X2.0	30	23,699	160
MGFR16T	MGFL16T	16	21	12.75	64	38.00	27	22	28.58	33	M16X2.0	33	25,162	215

**SELF-LUBRICATING**

This series features a self-lubricating PTFE liner and a 300 series stainless steel body for corrosive environments.



**MCM & MCF**

**Features**

**BALL**

- 52100 Bearing Steel
- Heat Treated
- Hard Chrome Plated
- Precision Ground

**BODY**

- Carbon Steel
- Protective Coated for Corrosion Resistance

PART NUMBER

DIMENSIONS IN MILLIMETERS

**MCM Male**

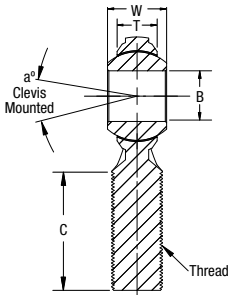
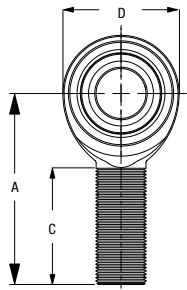

Right Hand	Left Hand	B + .065 - .012	W ± .12	T Ref.	A ± .40	D Ref.	Ball Dia. Ref.	C ± 1.00	Thread 6g	Misalign. Angle a°	Ult. Radial Static Load (Newtons)	Approx. Brg. Wgt. (Grams)
MCMR5*	MCML5*	5	8	5.75	33	16.00	11.10	20	M5X.08	22	5,168	12
MCMR6*	MCML6*	6	9	6.25	36	19.00	12.70	22	M6X1.0	23	7,296	18
MCMR8*	MCML8*	8	12	8.00	42	22.25	15.88	25	M8X1.25	28	13,591	31
MCMR10	MCML10	10	14	9.50	48	27.00	19.05	29	M10X1.5	26	21,024	68
MCMR12	MCML12	12	16	10.75	54	30.00	22.23	33	M12X1.75	27	25,819	78
MCMR14	MCML14	14	19	12.25	60	34.75	25.40	36	M14X2.0	30	35,214	118
MCMR16	MCML16	16	21	12.75	66	38.00	28.58	40	M16X2.0	33	37,391	173
MCMR20	MCML20	20	25	16.25	78	46.00	34.93	47	M20X1.5	29	57,101	290

PART NUMBER

DIMENSIONS IN MILLIMETERS

**MCF Female**

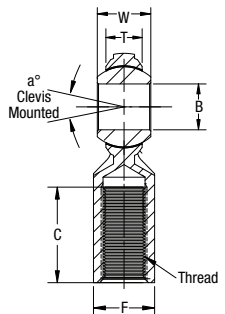
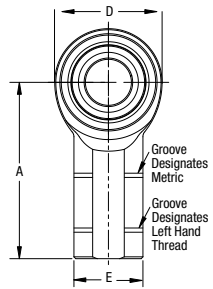

Right Hand	Left Hand	B + .065 - .012	W ± .12	T Ref.	A ± .40	D Ref.	E ± .25	F ± .25	Ball Dia. Ref.	C ± 1.00	Thread 6H	Misalign. Angle a°	Ult. Radial Static Load (Newtons)	Approx. Brg. Wgt. (Grams)
MCFR5*	MCFL5*	5	8	5.75	27	16.00	11	9	11.10	14	M5X.08	22	8,247	18
MCFR6	MCFL6	6	9	6.25	30	19.00	13	11	12.70	14	M6X1.0	23	11,895	25
MCFR8	MCFL8	8	12	8.00	36	22.25	16	14	15.88	17	M8X1.25	28	15,190	40
MCFR10	MCFL10	10	14	9.50	43	27.00	19	17	19.05	21	M10X1.5	26	22,750	80
MCFR12	MCFL12	12	16	10.75	50	30.00	22	19	22.23	24	M12X1.75	27	25,819	95
MCFR14	MCFL14	14	19	12.25	57	34.75	25	22	25.40	27	M14X2.0	30	35,214	160
MCFR16	MCFL16	16	21	12.75	64	38.00	27	22	28.58	33	M16X2.0	33	37,391	215
MCFR20	MCFL20	20	25	16.25	77	46.00	34	30	34.93	40	M20X1.5	29	57,101	350

The MC Series is defined as economical, commercial grade rod ends that are generally appropriate for moderate applications.

Load ratings apply only to rod ends without grease fittings.  
For ratings with grease fittings, please contact us.

# MHM & MHF Alloy Steel

Alloy Race - Right & Left Hand Threads - Male & Female

**P R E C I S I O N**

**Metric  
3-Piece  
Rod Ends**

**QA1**

## MHM & MHF Features

### BALL

- 52100 Bearing Steel
- Heat Treated
- Hard Chrome Plated

### RACE

- Alloy Steel
- Heat Treated

### BODY

- Alloy Steel
- Heat Treated
- Protective Coated for Corrosion Resistance

### PART NUMBER

### DIMENSIONS IN MILLIMETERS

## MHM Male

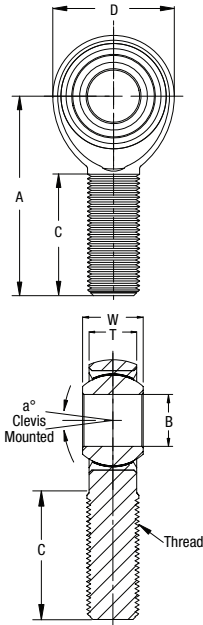

Right Hand	Left Hand	B + .065 - .012	W ± .12	T ± .12	A ± .40	D ± .38	Ball Dia. Ref.	C ± 1.0	Thread 6g	Misalign. Angle a°	Ult. Radial Static Load (Newtons)	Approx. Brg. Wgt. (Grams)
MHMR5	MHML5	5	8	6.25	33	16.00	11.10	20	M5X0.8	14	12,611	13
MHMR6	MHML6	6	9	7.00	36	19.00	12.70	22	M6X1.0	13	17,720	18
MHMR8	MHML8	8	12	8.75	42	22.25	15.88	25	M8X1.25	18	33,135	31
MHMR8-1	MHML8-1	8	12	8.75	42	22.25	15.88	25	M8X1.0	18	33,135	36
MHMR10	MHML10	10	14	10.50	48	27.00	19.05	29	M10X1.5	17	50,227	68
MHMR10-1	MHML10-1	10	14	10.50	48	27.00	19.05	29	M10X1.25	17	50,227	62
MHMR12	MHML12	12	16	12.00	54	30.00	22.23	33	M12X1.75	17	44,490	78
MHMR12-1	MHML12-1	12	16	12.00	54	30.00	22.23	33	M12X1.25	17	44,490	88
MHMR14	MHML14	14	19	13.50	60	34.75	25.40	36	M14X2.0	21	71,741	118
MHMR14-1	MHML14-1	14	19	13.50	60	34.75	25.40	36	M14X1.5	21	71,741	134
MHMR16	MHML16	16	21	14.25	66	38.00	28.58	40	M16X2.0	23	76,291	173
MHMR16-1	MHML16-1	16	21	14.25	66	38.00	28.58	40	M16X1.5	23	76,291	178
MHMR20	MHML20	20	25	18.00	78	46.00	34.93	47	M20X1.5	20	120,212	290
MHMR20-1	MHML20-1	20	25	18.00	78	46.00	34.93	47	M20X2.5	20	120,212	330

### PART NUMBER

### DIMENSIONS IN MILLIMETERS

## MHF Female

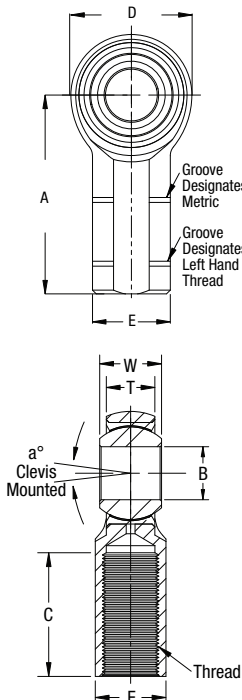

Right Hand	Left Hand	B + .065 - .012	W ± .12	T ± .12	A ± .40	D ± .38	E ± .25	F ± .25	Ball Dia. Ref.	C ± 1.0	Thread 6H	Misalign. Angle a°	Ult. Radial Static Load (Newtons)	Approx. Brg. Wgt. (Grams)
MHFR5	MHFL5	5	8	6.25	27	16.00	11	9	11.10	14	M5X0.8	14	16,396	17
MHFR6	MHFL6	6	9	7.00	30	19.00	13	11	12.70	14	M6X1.0	13	23,535	25
MHFR8	MHFL8	8	12	8.75	36	22.25	16	14	15.88	17	M8X1.25	18	33,203	40
MHFR8-1	MHFL8-1	8	12	8.75	36	22.25	16	14	15.88	17	M8X1.0	18	33,203	54
MHFR10	MHFL10	10	14	10.50	43	27.00	19	17	19.05	21	M10X1.5	17	50,227	80
MHFR10-1	MHFL10-1	10	14	10.50	43	27.00	19	17	19.05	21	M10X1.25	17	50,227	91
MHFR12	MHFL12	12	16	12.00	50	30.00	22	19	22.23	24	M12X1.75	17	44,490	95
MHFR12-1	MHFL12-1	12	16	12.00	50	30.00	22	19	22.23	24	M12X1.25	17	44,490	132
MHFR14	MHFL14	14	19	13.50	57	34.75	25	22	25.40	27	M14X2.0	21	71,741	160
MHFR14-1	MHFL14-1	14	19	13.50	57	34.75	25	22	25.40	27	M14X1.5	21	71,741	196
MHFR16	MHFL16	16	21	14.25	64	38.00	27	22	28.58	33	M16X2.0	23	76,291	215
MHFR16-1	MHFL16-1	16	21	14.25	64	38.00	27	22	28.58	33	M16X1.5	23	76,291	240
MHFR20	MHFL20	20	25	18.00	77	46.00	34	30	34.93	40	M20X1.5	20	120,212	350
MHFR20-1	MHFL20-1	20	25	18.00	77	46.00	34	30	34.93	40	M20X2.5	20	120,212	456

The MH Series consists of precision rod ends that have higher ball-to-race conformity, which creates tighter tolerances. This makes them ideal for critical applications where precision tolerances are a must.

## MHM-T & MHF-T Features

### BALL

- 52100 Bearing Steel
- Heat Treated
- Hard Chrome Plated

### RACE

- Stainless Steel
- Heat Treated
- PTFE Lined

### BODY

- Alloy Steel
- Heat Treated
- Protective Coated for Corrosion Resistance

### PART NUMBER

### DIMENSIONS IN MILLIMETERS

## MHM-T Male

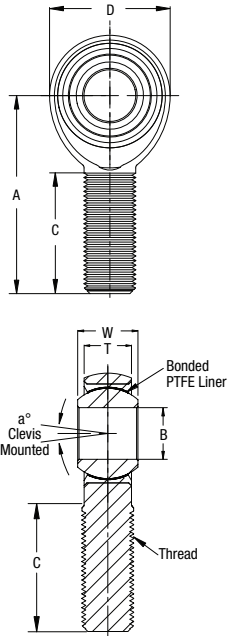

Right Hand	Left Hand	B + .065 - .012	W ± .12	T ± .12	A ± .40	D ± .38	Ball Dia. Ref.	C ± 1.0	Thread 6g	Misalign. Angle a°	Ult. Radial Static Load (Newtons)	Approx. Brg. Wgt. (Grams)
MHMR5T	MHML5T	5	8	6.25	33	16.00	11.10	20	M5X0.8	14	12,611	13
MHMR6T	MHML6T	6	9	7.00	36	19.00	12.70	22	M6X1.0	13	17,720	18
MHMR8T	MHML8T	8	12	8.75	42	22.25	15.88	25	M8X1.25	18	33,135	31
MHMR8T-1	MHML8T-1	8	12	8.75	42	22.25	15.88	25	M8X1.0	18	33,135	36
MHMR10T	MHML10T	10	14	10.50	48	27.00	19.05	29	M10X1.5	17	50,227	68
MHMR10T-1	MHML10T-1	10	14	10.50	48	27.00	19.05	29	M10X1.25	17	50,227	62
MHMR12T	MHML12T	12	16	12.00	54	30.00	22.23	33	M12X1.75	17	44,490	78
MHMR12T-1	MHML12T-1	12	16	12.00	54	30.00	22.23	33	M12X1.25	17	44,490	88
MHMR14T	MHML14T	14	19	13.50	60	34.75	25.40	36	M14X2.0	21	71,741	118
MHMR14T-1	MHML14T-1	14	19	13.50	60	34.75	25.40	36	M14X1.5	21	71,741	134
MHMR16T	MHML16T	16	21	14.25	66	38.00	28.58	40	M16X2.0	23	76,291	173
MHMR16T-1	MHML16T-1	16	21	14.25	66	38.00	28.58	40	M16X1.5	23	76,291	178
MHMR20T	MHML20T	20	25	18.00	78	46.00	34.93	47	M20X1.5	20	120,212	290
MHMR20T-1	MHML20T-1	20	25	18.00	78	46.00	34.93	47	M20X2.5	20	120,212	330

## SELF-LUBRICATING

### PART NUMBER

### DIMENSIONS IN MILLIMETERS

## MHF-T Female

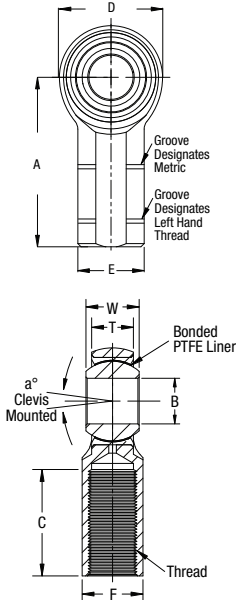

Right Hand	Left Hand	B + .065 - .012	W ± .12	T ± .12	A ± .40	D ± .38	E ± .25	F ± .25	Ball Dia. Ref.	C ± 1.0	Thread 6H	Misalign. Angle a°	Ult. Radial Static Load (Newtons)	Approx. Brg. Wgt. (Grams)
MHFR5T	MHFL5T	5	8	6.25	27	16.00	11	9	11.10	14	M5X0.8	14	16,396	17
MHFR6T	MHFL6T	6	9	7.00	30	19.00	13	11	12.70	14	M6X1.0	13	23,535	25
MHFR8T	MHFL8T	8	12	8.75	36	22.25	16	14	15.88	17	M8X1.25	18	33,203	40
MHFR8T-1	MHFL8T-1	8	12	8.75	36	22.25	16	14	15.88	17	M8X1.0	18	33,203	54
MHFR10T	MHFL10T	10	14	10.50	43	27.00	19	17	19.05	21	M10X1.5	17	50,227	80
MHFR10T-1	MHFL10T-1	10	14	10.50	43	27.00	19	17	19.05	21	M10X1.25	17	50,227	91
MHFR12T	MHFL12T	12	16	12.00	50	30.00	22	19	22.23	24	M12X1.75	17	44,490	95
MHFR12T-1	MHFL12T-1	12	16	12.00	50	30.00	22	19	22.23	24	M12X1.25	17	44,490	132
MHFR14T	MHFL14T	14	19	13.50	57	34.75	25	22	25.40	27	M14X2.0	21	71,741	160
MHFR14T-1	MHFL14T-1	14	19	13.50	57	34.75	25	22	25.40	27	M14X1.5	21	71,741	196
MHFR16T	MHFL16T	16	21	14.25	64	38.00	27	22	28.58	33	M16X2.0	23	76,291	215
MHFR16T-1	MHFL16T-1	16	21	14.25	64	38.00	27	22	28.58	33	M16X1.5	23	76,291	240
MHFR20T	MHFL20T	20	25	18.00	77	46.00	34	30	34.93	40	M20X1.5	20	120,212	350
MHFR20T-1	MHFL20T-1	20	25	18.00	77	46.00	34	30	34.93	40	M20X2.5	20	120,212	456

## SELF-LUBRICATING

# MVM & MVF Carbon Steel

Bronze Race - Right & Left Hand Threads - Male & Female

**C O M M E R C I A L**

**Metric  
3-Piece  
Rod Ends**

**QA1**

## MVM & MVF Features

### BALL

- 52100 Bearing Steel
- Heat Treated
- Hard Chrome Plated
- Precision Ground

### RACE

- Sintered Bronze
- Oil Impregnated

### BODY

- Carbon Steel
- Protective Coated for Corrosion Resistance

PART NUMBER

DIMENSIONS IN MILLIMETERS

## MVM Male

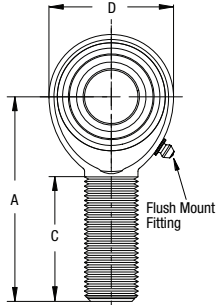

Right Hand	Left Hand	B + .065 - .012	W + .000 - .13	T ± .12	A ± .4	D ± .38	Ball Dia. Ref.	C + 1.5 - .75	Thread 6g	Misalign. Angle a°	Ult. Radial Static Load (Newtons)	Approx. Brg. Wgt. (Grams)
MVMR5*	MVML5*	5	8	6.25	33	16.00	11.10	20	M5X.08	14	8,114	13
MVMR6*	MVML6*	6	9	7.00	36	19.00	12.70	22	M6X1.0	13	11,486	20
MVMR8	MVML8	8	12	8.75	42	22.25	15.88	25	M8X1.25	18	17,839	36
MVMR10	MVML10	10	14	10.50	48	27.00	19.05	29	M10X1.5	17	27,989	62
MVMR12	MVML12	12	16	12.00	54	30.00	22.23	33	M12X1.75	17	34,688	89
MVMR14	MVML14	14	19	13.50	60	34.75	25.40	36	M14X2.0	21	44,337	134
MVMR16	MVML16	16	21	14.25	66	38.00	28.58	40	M16X2.0	23	48,257	178
MVMR20	MVML20	20	25	18.00	78	46.00	34.93	47	M20X1.5	20	68,587	332

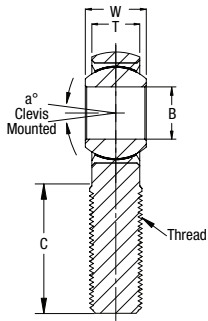

PART NUMBER

DIMENSIONS IN MILLIMETERS

## MVF Female

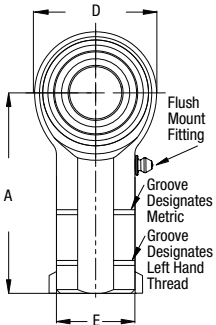

Right Hand	Left Hand	B + .065 - .012	W + .000 - .13	T ± .12	A ± .4	D ± .38	E ± .25	F ± .25	Ball Dia. Ref.	C + 1.5 - .75	Thread 6H	Misalign. Angle a°	Ult. Radial Static Load (Newtons)	Approx. Brg. Wgt. (Grams)
MVFR5*	MVFL5*	5	8	6.25	27	16.00	11	9	11.10	14	M5X.08	14	10,274	19
MVFR6*	MVFL6*	6	9	7.00	30	19.00	13	11	12.70	14	M6X1.0	13	15,771	29
MVFR8	MVFL8	8	12	8.75	36	22.25	16	14	15.88	17	M8X1.25	18	17,839	51
MVFR10	MVFL10	10	14	10.50	43	27.00	19	17	19.05	21	M10X1.5	17	27,989	86
MVFR12	MVFL12	12	16	12.00	50	30.00	22	19	22.23	24	M12X1.75	17	34,688	124
MVFR14	MVFL14	14	19	13.50	57	34.75	25	22	25.40	27	M14X2.0	21	44,337	184
MVFR16	MVFL16	16	21	14.25	64	38.00	27	22	28.58	33	M16X2.0	23	48,257	223
MVFR20	MVFL20	20	25	18.00	77	46.00	34	30	34.93	40	M20X1.5	20	68,587	436

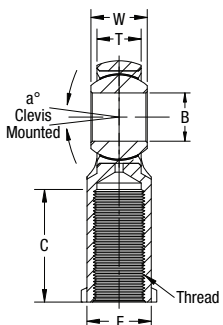

Spherical bearings are used wherever rotational motion is needed to change the alignment of an axis. QA1's spherical bearings are available in a wide variety of sizes, styles and materials, with or without PTFE liners. Custom sizes and materials are available upon request and minimum orders apply.

## FRACTURED RACE SPHERICAL BEARINGS

QA1's GEZ Series uses hardened, ground bearing steel on both the race and the ball. All surfaces of the part are ground for smooth ball rotation. The grinding operations create an assembly that has full ball to race contact, thus reducing localized stress and wear. Due to the extreme strength, this series is particularly well-suited for high wear and high load applications.

### INCH SERIES

- GEZ - Bearing Steel
- GEZ-2RS - Bearing Steel - Sealed



## INJECTION MOLDED SPHERICAL BEARINGS

QA1's EMB Series spherical bearings feature an injection molded nylon race for superior ball to race conformity. This race results in the bearing being completely self-sealing and self-lubricating, keeping dirt and debris out. EMB Series spherical bearings are ideal for low load, low oscillation applications.

### INCH SERIES

- EMB - Bearing Steel - Nylon Race
- EMB Wide Ball - Bearing Steel - Nylon Race



## COMMERCIAL SPHERICAL BEARINGS

QA1's COM Series is a traditional commercial bearing made from alloy steel with an optional self-lubricating PTFE liner (COM-T). The COM-SS Series is made from stainless steel. Bore sizes ranging from 1 to 2 inches are also available with the HCOM Series.

### INCH SERIES

- COM - Bearing Steel - Alloy Steel Race
- COM-T - Bearing Steel - Alloy Steel Race - PTFE Lined
- COM-SS - Stainless Steel
- HCOM - Bearing Steel - Alloy Steel Race
- HCOM-T - Bearing Steel - Alloy Steel Race - PTFE Lined

### METRIC SERIES

- MCOM - Bearing Steel - Alloy Steel Race
- MCOM-T - Bearing Steel - Alloy Steel Race - PTFE Lined



## PRECISION SPHERICAL BEARINGS

QA1's precision line of spherical bearings are made from stainless steel with a PTFE liner. Our NPB-T Series bearings are narrow, offering tighter tolerances than traditional bearings. The YPB-T Series bearings are a great choice if your application requires high misalignment. QA1's WPB-T wide bearings offer tighter tolerances and are available with an optional staking groove (WPB-TG).

### INCH SERIES

- NPB-T - Narrow - Stainless Steel - PTFE Lined
- YPB-T - High Misalignment - Stainless Steel - PTFE Lined
- WPB-T - Wide - Stainless Steel - PTFE Lined
- WPB-TG - Wide - Stainless Steel - PTFE Lined - Staking Groove



## UNIQUE DIMENSION SPHERICAL BEARINGS

QA1 offers a variety of spherical bearings for projects that require unique dimensions. With an increased race width and diameter, QA1's AIB alloy steel bearings, MIB carbon steel bearings and SIB stainless steel bearings offer improved wear characteristics. These series are all available with an optional self-lubricating PTFE liner and are corrosion resistant, giving them increased longevity.

### INCH SERIES

- MIB - Bearing Steel - Low Carbon Steel Race
- MIB-T - Bearing Steel - Low Carbon Steel Race - PTFE Lined
- AIB - Bearing Steel - Alloy Steel Race
- AIB-T - Bearing Steel - Alloy Steel Race - PTFE Lined
- SIB - Bearing Steel - Stainless Steel Race
- SIB-T - Bearing Steel - Stainless Steel Race - PTFE Lined



# GEZ & GEZ-2RS

Fractured Race - Sealed (2RS)

**C O M M E R C I A L**

Inch  
Spherical  
Bearings

**QA1**

## GEZ & GEZ-2RS Features

### BALL

- 52100 Bearing Steel
- Protective Coated for Corrosion Resistance

### RACE

- 52100 Bearing Steel
- Protective Coated for Corrosion Resistance
- 2 Rubber Seals (2RS)

## GEZ & GEZ-2RS Tolerances

In the GEZ series, tolerances differ based on the size of the spherical bearing. Use this table to determine the tolerances for each specific spherical bearing.

Sizes	B	D	W	T
12-15	+ .0000 - .0003	+ .0000 - .0003	+ .000 - .005	+ .000 - .009
19-25	+ .0000 - .0004	+ .0000 - .00035	+ .000 - .005	+ .000 - .009
31-44	+ .0000 - .0005	+ .0000 - .0004	+ .000 - .005	+ .000 - .009
50-76	+ .0000 - .0006	+ .0000 - .0005	+ .000 - .006	+ .000 - .012

### PART NUMBER

### DIMENSIONS IN INCHES

## GEZ & GEZ-2RS

Metal to Metal	Sealed	B	D	T	W	Ball Dia. Ref.	R <sub>1s</sub>	R <sub>2s</sub>	Misalign. Angle a°	Ult. Radial Static Load Lbs.	Approx. Brg. Wgt. Lbs.
GEZ12ES	-	0.500	0.875	0.375	0.437	0.709	0.012	0.024	6.0	9,217	0.05
GEZ15ES	-	0.625	1.063	0.469	0.547	0.906	0.012	0.024	6.0	14,613	0.08
GEZ19ES	GEZ19ES2RS	0.750	1.250	0.562	0.656	1.083	0.012	0.024	6.0	21,357	0.12
GEZ22ES	GEZ22ES2RS	0.875	1.438	0.656	0.765	1.260	0.012	0.024	6.0	28,551	0.19
GEZ25ES	GEZ25ES2RS	1.000	1.625	0.750	0.875	1.437	0.012	0.024	6.0	37,318	0.27
GEZ31ES	GEZ31ES2RS	1.250	2.000	0.937	1.093	1.791	0.024	0.024	6.0	58,450	0.51
GEZ34ES	GEZ34ES2RS	1.375	2.188	1.031	1.187	1.929	0.024	0.039	6.0	69,691	0.77
GEZ38ES	GEZ38ES2RS	1.500	2.438	1.125	1.312	2.154	0.024	0.039	6.0	84,303	0.93
GEZ44ES	GEZ44ES2RS	1.750	2.813	1.312	1.531	2.516	0.024	0.039	6.0	114,653	1.41
GEZ50ES	GEZ50ES2RS	2.000	3.188	1.500	1.750	2.874	0.024	0.039	6.0	150,622	2.05
GEZ57ES	GEZ57ES2RS	2.250	3.563	1.687	2.166	3.228	0.024	0.039	6.0	191,088	2.93
GEZ63ES	GEZ63ES2RS	2.500	3.938	1.875	2.187	3.622	0.024	0.039	6.0	238,298	4.08
GEZ69ES	GEZ69ES2RS	2.750	4.375	2.062	2.406	3.937	0.039	0.039	6.0	281,011	5.34
GEZ76ES	GEZ76ES2RS	3.000	4.750	2.250	2.625	4.311	0.039	0.039	6.0	337,213	6.83

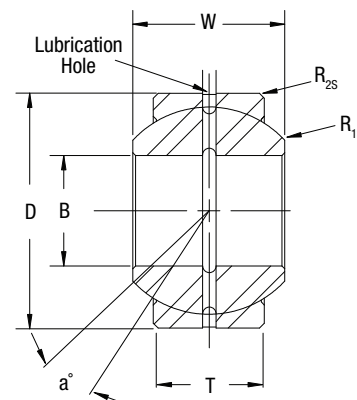
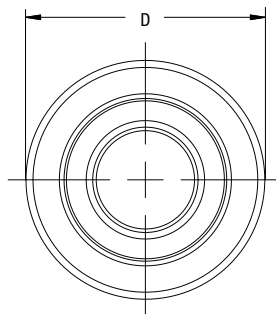

Spherical Bearings

# COM(-T), HCOM(-T) & COM-SS

Alloy Race, PTFE Lined Optional (COM(-T), HCOM(-T)) - Stainless Steel (COM-SS)

**C O M M E R C I A L**

### COM(-T), HCOM(-T) Features

#### BALL

- 52100 Bearing Steel
- Heat Treated
- Hard Chrome Plated
- Precision Ground

#### RACE

- Alloy Steel
- Heat Treated
- PTFE Lined Optional
- Protective Coated

#### PART NUMBER

#### DIMENSIONS IN INCHES

### COM(-T), HCOM(-T)

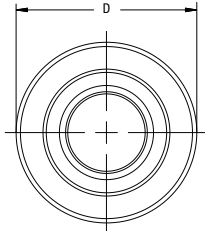

**NEW PRODUCT**

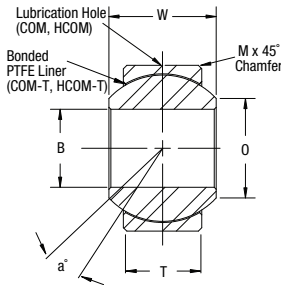

COM Series Metal-to-Metal	COM-T Series PTFE Lined	B + .0015 - .0005	D + .0000 - .0007	T ± .005	W ± .005	O Flat Dia. Ref.	M Cham. Ref.	Ball Dia. Ref.	Misalign. Angle a°	Ult. Radial Static Load Lbs.	Approx. Brg. Wgt. Lbs.
COM2	-	0.1650	0.4687	0.187	0.250	0.235	0.020	0.343	9.0	3,200	0.01
COM3	COM3T	0.1900	0.5625	0.218	0.281	0.293	0.015	0.406	11.0	4,875	0.01
COM4	COM4T	0.2500	0.6562	0.250	0.343	0.364	0.022	0.500	13.5	7,425	0.02
COM5	COM5T	0.3125	0.7500	0.281	0.375	0.419	0.032	0.562	12.0	9,713	0.03
COM6	COM6T	0.3750	0.8125	0.312	0.406	0.516	0.032	0.656	10.0	12,600	0.04
COM7	COM7T	0.4375	0.9062	0.343	0.437	0.530	0.032	0.687	8.0	14,180	0.05
COM8	COM8T	0.5000	1.0000	0.390	0.500	0.640	0.032	0.781	9.5	19,875	0.07
COM8-107	COM8T-107	.500	1.0000	0.390	0.625	0.612	0.032	0.875	9.5	18,975	.07
COM9	COM9T	0.5625	1.0937	0.437	0.562	0.710	0.032	0.875	9.5	24,945	0.09
COM10	COM10T	0.6250	1.1875	0.500	0.625	0.780	0.032	0.968	8.5	31,920	0.11
COM12	COM12T	0.7500	1.4375	0.593	0.750	0.920	0.044	1.187	9.0	47,880	0.20
COM12-757	-	0.7570	1.4375	0.593	0.750	0.920	0.044	1.187	9.0	47,880	0.20
COM14	COM14T	0.8750	1.5625	0.703	0.875	0.980	0.044	1.312	9.5	62,940	0.26
COM16	COM16T	1.0000	1.7500	0.797	1.000	1.118	0.044	1.500	10.0	82,800	0.39
HCOM16	HCOM16T	1.0000	2.0000	0.781	1.000	1.360	0.032	1.687	9.0	106,230	0.55
HCOM19	HCOM19T	1.1875	2.3750	0.937	1.187	1.610	0.032	2.000	8.5	151,095	0.90
HCOM20	HCOM20T	1.2500	2.3750	0.937	1.187	1.610	0.032	2.000	8.5	151,095	0.90
HCOM24	HCOM24T	1.5000	2.7500	1.094	1.375	1.860	0.032	2.312	8.5	203,925	1.36
HCOM28	-	1.7500	3.1250	1.250	1.562	2.110	0.044	2.625	8.0	264,555	1.95
HCOM32	HCOM32T	2.0000	3.5000	1.375	1.750	2.360	0.044	2.937	8.5	325,590	2.66

### COM-SS Features

#### BALL

- 440C Stainless Steel
- Heat Treated
- Hard Chrome Plated
- Precision Ground

#### RACE

- 300 Series Stainless Steel

#### PART NUMBER

#### DIMENSIONS IN INCHES

### COM-SS

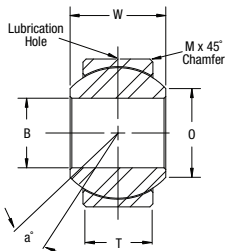
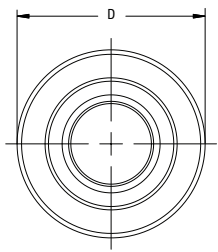

Part Number	B + .0015 - .0005	D + .0000 - .0007	T ± .005	W ± .005	O Flat Dia. Ref.	M Cham. Ref.	Ball Dia. Ref.	Misalign. Angle a°	Ult. Radial Static Load Lbs.	Approx. Brg. Wgt. Lbs.
COM2SS	0.1650	0.4687	0.187	0.250	0.235	0.020	0.343	9.0	3,200	0.01
COM3SS	0.1900	0.5625	0.218	0.281	0.293	0.020	0.406	11.0	4,400	0.01
COM4SS	0.2500	0.6562	0.250	0.343	0.364	0.022	0.500	13.5	6,700	0.02
COM5SS	0.3125	0.7500	0.281	0.375	0.419	0.032	0.562	12.0	9,200	0.03
COM6SS	0.3750	0.8125	0.312	0.406	0.516	0.032	0.656	10.0	12,400	0.04
COM7SS	0.4375	0.9062	0.343	0.437	0.530	0.032	0.687	8.0	14,900	0.05
COM8SS	0.5000	1.0000	0.390	0.500	0.640	0.032	0.781	9.5	17,900	0.07
COM9SS	0.5625	1.0937	0.437	0.562	0.710	0.032	0.875	9.5	23,700	0.09
COM10SS	0.6250	1.1875	0.500	0.625	0.780	0.032	0.968	8.5	32,000	0.11
COM12SS	0.7500	1.4375	0.593	0.750	0.920	0.044	1.187	9.0	48,000	0.20
COM14SS	0.8750	1.5625	0.703	0.875	0.980	0.044	1.312	9.5	69,000	0.26
COM16SS	1.0000	1.7500	0.797	1.000	1.118	0.044	1.500	10.0	83,000	0.39

# WPB-T & WPB-TG

Wide Series - Stainless Steel - PTFE Lined

P R E C I S I O N

Inch  
Spherical  
Bearings

# QA1

## WPB-T & WPB-TG Features

### BALL

- 440C Stainless Steel
- Heat Treated
- Hard Chrome Plated
- Precision Ground

### RACE

- Stainless Steel
- Heat Treated
- PTFE Lined
- Staking Groove Optional (WPB-TG)

DIMENSIONS IN INCHES

## WPB-T

Part Number	B + .0000 - .0005	D + .0000 - .0005	T ± .005	W + .000 - .002	O Flat Dia. Ref.	M Cham. Ref.	Ball Dia. Ref.	Misalign. Angle a°	Ult. Radial Static Load Lbs.	Ult. Axial Static Load Lbs.	No Load Breakaway Torque In. Lbs.	Approx. Brg. Wgt. Lbs.
WPB4T	0.2500	0.6250	0.327	0.437	0.300	0.022	0.531	15	5,500	1,770	0.25-5	0.03
WPB5T	0.3125	0.6875	0.317	0.437	0.360	0.032	0.593	14	9,400	1,640	1-8	0.04
WPB6T	0.3750	0.8125	0.406	0.500	0.466	0.032	0.687	8	13,700	2,630	1-8	0.06
WPB8T	0.5000	1.0000	0.505	0.625	0.607	0.032	0.875	9	21,400	4,970	3-12	0.10
WPB9T	0.5625	1.1250	0.536	0.687	0.721	0.032	1.000	10	26,600	5,370	3-12	0.14
WPB10T	0.6250	1.1875	0.567	0.750	0.752	0.032	1.062	12	29,000	6,130	3-12	0.16
WPB12T	0.7500	1.3750	0.630	0.875	0.845	0.044	1.250	13	37,000	7,730	3-12	0.24
WPB14T	0.8750	1.6250	0.755	0.875	0.995	0.044	1.375	6	65,200	10,800	3-12	0.35
WPB16T	1.0000	2.1250	1.005	1.375	1.269	0.044	1.875	12	104,000	19,300	3-12	0.97

## SELF-LUBRICATING

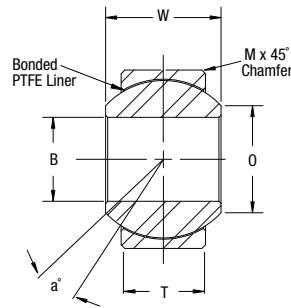
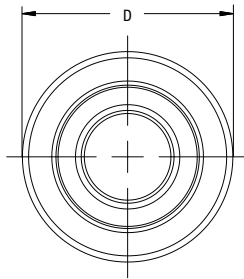

DIMENSIONS IN INCHES

## WPB-TG Staking Groove

Part Number	B + .0000 - .0005	D + .0000 - .0005	T ± .005	W + .000 - .002	O Flat Dia. Ref.	P + .000 - .015	R + .002 - .005	S Min.	G + .000 - .010	Ball Dia. Ref.	Misalign. Angle a°	Ult. Radial Static Load Lbs.	Ult. Axial Static Load Lbs.	No Load Breakaway Torque In. Lbs.	Approx. Brg. Wgt. Lbs.
WPB4TG	0.2500	0.6250	0.327	0.437	0.300	0.030	0.010	0.010	0.565	0.531	15	5,500	1,770	0.25-5	0.03
WPB5TG	0.3125	0.6875	0.317	0.437	0.360	0.030	0.010	0.010	0.627	0.593	14	9,400	1,640	1-8	0.04
WPB6TG	0.3750	0.8125	0.406	0.500	0.466	0.040	0.015	0.020	0.714	0.687	8	13,700	2,630	1-8	0.06
WPB7TG	0.4375	0.9375	0.442	0.562	0.537	0.040	0.015	0.020	0.839	0.781	10	20,700	3,650	3-12	0.08
WPB8TG	0.5000	1.0000	0.505	0.625	0.607	0.040	0.015	0.020	0.902	0.875	9	21,400	4,970	3-12	0.10
WPB9TG	0.5625	1.1250	0.536	0.687	0.721	0.040	0.015	0.020	1.027	1.000	10	26,600	5,370	3-12	0.14
WPB10TG	0.6250	1.1875	0.567	0.750	0.752	0.040	0.015	0.020	1.089	1.062	12	29,000	6,130	3-12	0.16
WPB12TG	0.7500	1.3750	0.630	0.875	0.845	0.060	0.015	0.020	1.253	1.250	13	37,000	7,730	3-12	0.24
WPB14TG	0.8750	1.6250	0.755	0.875	0.995	0.060	0.015	0.020	1.503	1.375	6	65,200	10,800	3-12	0.35

## SELF-LUBRICATING

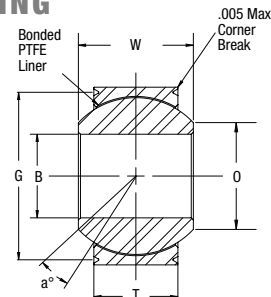
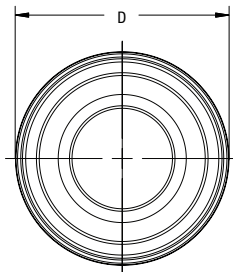



# NPB-T & YPB-T

Narrow (NPB-T) - High Misalignment (YPB-T) - Stainless Steel - PTFE Lined

**P R E C I S I O N**

### NPB-T & YPB-T Features

#### BALL

- 440C Stainless Steel
- Heat Treated

- Hard Chrome Plated
- Precision Ground

#### RACE

- Stainless Steel
- Heat Treated
- PTFE Lined

DIMENSIONS IN INCHES

### NPB-T Narrow

Part Number	B + .0000 - .0005	D + .0000 - .0005	T ± .005	W + .000 - .002	O Flat Dia. Ref.	M Cham. Ref.	Ball Dia. Ref.	Misalign. Angle a°	Ult. Radial Static Load Lbs.	Ult. Axial Static Load Lbs.	No Load Breakaway Torque In.-Lbs.	Approx. Brg. Wgt. Lbs.
NPB3T	0.1900	0.5625	0.218	0.281	0.293	0.015	0.406	10	3,975	150	0.25-5	0.02
NPB4T	0.2500	0.6562	0.250	0.343	0.364	0.022	0.500	10	6,040	430	0.25-5	0.02
NPB5T	0.3125	0.7500	0.281	0.375	0.419	0.032	0.562	10	8,750	700	1-8	0.03
NPB6T	0.3750	0.8125	0.312	0.406	0.475	0.032	0.656	9	10,540	1,100	1-8	0.04
NPB7T	0.4375	0.9062	0.343	0.437	0.530	0.032	0.687	8	13,200	1,400	3-12	0.05
NPB8T	0.5000	1.0000	0.390	0.500	0.600	0.032	0.781	8	17,900	2,100	3-12	0.07
NPB9T	0.5625	1.0937	0.437	0.562	0.670	0.032	0.875	8	23,200	3,680	3-12	0.09
NPB10T	0.6250	1.1875	0.500	0.625	0.739	0.032	0.968	8	30,500	4,720	3-12	0.12
NPB12T	0.7500	1.4375	0.593	0.750	0.920	0.044	1.187	8	46,400	6,750	3-12	0.21
NPB14T	0.8750	1.5625	0.703	0.875	0.980	0.044	1.312	8	62,200	9,350	3-12	0.27
NPB16T	1.0000	1.7500	0.797	1.000	1.118	0.044	1.500	9	82,200	12,160	3-12	0.39

### SELF-LUBRICATING

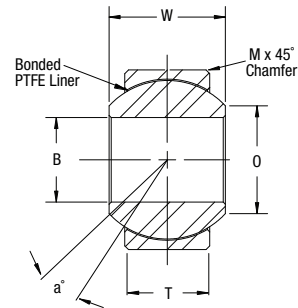
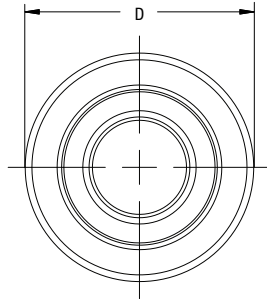

DIMENSIONS IN INCHES

### YPB-T High Misalignment

Part Number	B + .0000 - .0005	D + .0000 - .0007	T ± .005	W + .000 - .005	O Flat Dia. Ref.	M Cham. Ref.	Ball Dia. Ref.	Misalign. Angle a°	Ult. Radial Static Load Lbs.	Approx. Brg. Wgt. Lbs.
YPB4T	0.2500	0.7400	0.255	0.593	0.390	0.020	0.593	24	7,560	0.04
YPB5T	0.3125	0.9060	0.345	0.813	0.512	0.030	0.781	23	16,975	0.07
YPB6T	0.3750	0.9060	0.345	0.813	0.512	0.030	0.781	23	16,975	0.07
YPB8T	0.5000	1.1250	0.401	0.937	0.730	0.030	1.000	20	25,263	0.16
YPB10T	0.6250	1.3750	0.567	1.200	0.856	0.030	1.250	20	44,651	0.25
YPB12T	0.7500	1.5625	0.620	1.280	0.970	0.035	1.325	18	53,507	0.32

### SELF-LUBRICATING

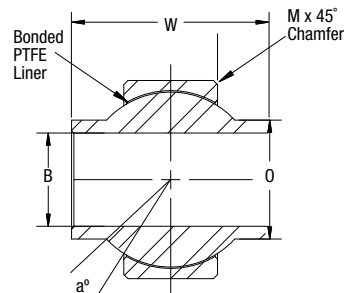
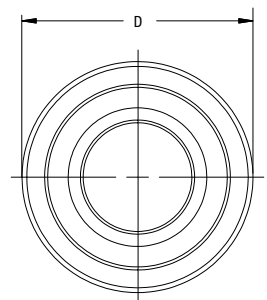

# MIB(-T), AIB(-T) & SIB(-T)

Alternative Construction - PTFE Lined Optional

**C O M M E R C I A L**

**Inch  
Spherical  
Bearings**

**QA1**

## MIB/MIB-T, AIB/AIB-T & SIB/SIB-T

### Features

#### BALL

- 52100 Bearing Steel
- Heat Treated
- Hard Chrome Plated
- Precision Ground

#### MIB RACE

- Low Carbon Steel
- I.D. Protective Coated for Corrosion Resistance
- Oil Coated
- Mfr. Option - Stainless Steel
- Heat Treated

#### AIB RACE

- Alloy Steel
- I.D. Protective Coated for Corrosion Resistance
- Oil Coated
- Mfr. Option - Stainless Steel
- Heat Treated

#### SIB RACE

- Stainless Steel
- Oil Coated
- Heat Treated

DIMENSIONS IN INCHES

## MIB, AIB & SIB

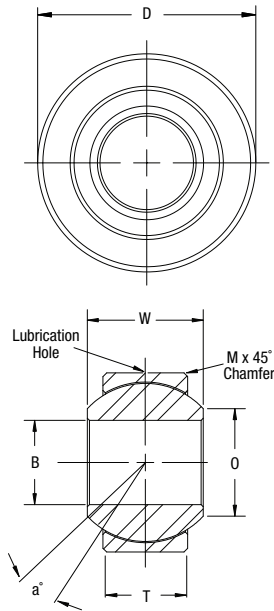

MIB Part Number	AIB Part Number	SIB Part Number	B + .0015 - .0005	D + .0000 - .0007	T ± .005	W + .000 - .005	O Flat Dia. Ref.	M Cham. Ref.	Ball Dia. Ref.	Misalign. Angle a°	Ult. Radial Load Lbs. MIB	Static Load Lbs. AIB/SIB	Approx. Brg. Wgt. Lbs.
MIB3	AIB3	SIB3	0.1900	0.5312	0.250	0.312	0.307	0.02	0.437	10.5	4,370	6,555	0.02
MIB4	AIB4	SIB4	0.2500	0.6094	0.281	0.375	0.331	0.02	0.500	14.5	5,620	8,430	0.02
MIB5	AIB5	SIB5	0.3125	0.7500	0.344	0.437	0.448	0.02	0.625	11.0	8,600	12,900	0.04
MIB6	AIB6	SIB6	0.3750	0.8437	0.406	0.500	0.516	0.02	0.719	9.5	11,677	17,516	0.06
MIB7	AIB7	SIB7	0.4375	1.0000	0.437	0.562	0.587	0.02	0.812	11.0	14,194	21,291	0.08
MIB8	AIB8	SIB8	0.5000	1.0937	0.500	0.625	0.699	0.02	0.937	9.5	18,740	28,110	0.11
MIB10	AIB10	SIB10	0.6250	1.3125	0.562	0.750	0.839	0.03	1.125	12.0	25,290	37,935	0.17
MIB12	AIB12	SIB12	0.7500	1.5000	0.687	0.875	0.978	0.03	1.312	10.0	32,448	48,672	0.25
MIB16	AIB16	SIB16	1.0000	2.1250	1.000	1.375	1.275	0.06	1.875	15.0	60,000	90,000	0.79

DIMENSIONS IN INCHES

## MIB-T, AIB-T & SIB-T

### PTFE Lined

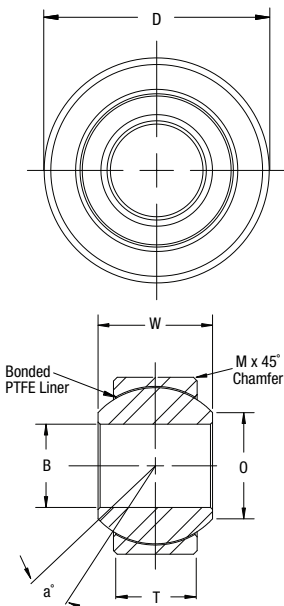

MIB-T Part Number	AIB-T Part Number	SIB-T Part Number	B + .0015 - .0005	D + .0000 - .0007	T ± .005	W + .000 - .005	O Flat Dia. Ref.	M Cham. Ref.	Ball Dia. Ref.	Misalign. Angle a°	Ult. Radial Load Lbs. MIB-T	Static Load Lbs. AIB-T/SIB-T	Approx. Brg. Wgt. Lbs.
MIB3T	AIB3T	SIB3T	0.1900	0.5312	0.250	0.312	0.307	0.02	0.437	10.5	4,370	6,555	0.02
MIB4T	AIB4T	SIB4T	0.2500	0.6094	0.281	0.375	0.331	0.02	0.500	14.5	5,620	8,430	0.02
MIB5T	AIB5T	SIB5T	0.3125	0.7500	0.344	0.437	0.448	0.02	0.625	11.0	8,600	12,900	0.04
MIB6T	AIB6T	SIB6T	0.3750	0.8437	0.406	0.500	0.516	0.02	0.719	9.5	11,677	17,516	0.06
MIB7T	AIB7T	SIB7T	0.4375	1.0000	0.437	0.562	0.587	0.02	0.812	11.0	14,194	21,291	0.08
MIB8T	AIB8T	SIB8T	0.5000	1.0937	0.500	0.625	0.699	0.02	0.937	9.5	18,740	28,110	0.11
MIB10T	AIB10T	SIB10T	0.6250	1.3125	0.562	0.750	0.839	0.03	1.125	12.0	25,290	37,935	0.17
MIB12T	AIB12T	SIB12T	0.7500	1.5000	0.687	0.875	0.978	0.03	1.312	10.0	32,448	48,672	0.25
MIB16T	AIB16T	SIB16T	1.0000	2.1250	1.000	1.375	1.275	0.06	1.875	15.0	60,000	90,000	0.79

**SELF-LUBRICATING**

### MCOM & MCOM-T

#### Features

#### BALL

- 52100 Steel
- Heat Treated

- Hard Chrome Plated
- Precision Ground

#### RACE

- Alloy Steel
- Heat Treated
- PTFE Lined Optional (MCOM-T)

DIMENSIONS IN MILLIMETERS

### MCOM

#### Metal-to-Metal

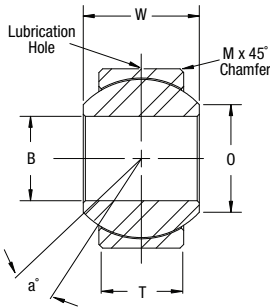
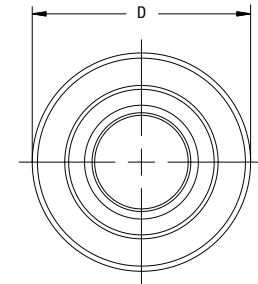

Part Number	B + .065 - .013	D + .000 - .018	T ± .13	W ± .13	O Flat Dia. Ref.	M Cham. Ref.	Ball Dia. Ref.	Misalign. Angle a°	Ult. Radial Static Load Cap. (Newtons)	Approx. Brg. Wgt. Grams
MCOM5	5	16	6.00	8	7.68	0.5	11.10	12.5	27,555	9
MCOM6	6	18	6.75	9	8.93	0.5	12.70	12.5	35,459	13
MCOM8	8	22	9.00	12	10.35	0.8	15.88	14.0	59,121	24
MCOM10	10	26	10.50	14	12.88	0.8	19.05	13.5	82,744	40
MCOM12	12	30	12.00	16	15.39	0.8	22.23	13.0	112,829	80
MCOM14	14	34	13.50	19	16.86	1.0	25.40	16.0	141,845	110
MCOM16	16	38	15.00	21	19.34	1.0	28.58	15.0	177,343	130
MCOM18	18	42	16.50	23	21.89	1.0	31.75	15.0	216,714	170
MCOM20	20	46	18.00	25	24.35	1.0	34.93	14.5	260,086	230
MCOM22	22	50	20.00	28	25.84	1.5	38.10	15.0	315,216	280
MCOM25	25	56	22.00	31	29.60	1.5	42.86	15.0	390,056	390
MCOM30	30	66	25.00	37	34.81	1.5	50.80	17.0	525,360	610

DIMENSIONS IN MILLIMETERS

### MCOM-T

#### PTFE Lined

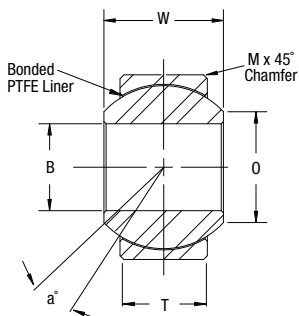
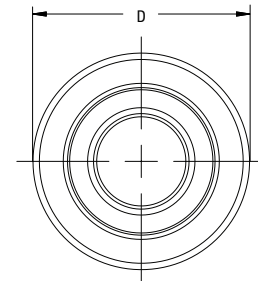

Part Number	B + .065 - .013	D + .000 - .018	T ± .13	W ± .13	O Flat Dia. Ref.	M Cham. Ref.	Ball Dia. Ref.	Misalign. Angle a°	Ult. Radial Static Load Cap. (Newtons)	Approx. Brg. Wgt. Grams
MCOM6T	6	18	6.75	9	8.93	0.5	12.70	12.5	35,459	13
MCOM8T	8	22	9.00	12	10.35	0.8	15.88	14.0	59,121	24
MCOM10T	10	26	10.50	14	12.88	0.8	19.05	13.5	82,744	40
MCOM12T	12	30	12.00	16	15.39	0.8	22.23	13.0	112,829	80
MCOM14T	14	34	13.50	19	16.86	1.0	25.40	16.0	141,845	110
MCOM16T	16	38	15.00	21	19.34	1.0	28.58	15.0	177,343	130
MCOM18T	18	42	16.50	23	21.89	1.0	31.75	15.0	216,714	170
MCOM20T	20	46	18.00	25	24.35	1.0	34.93	14.5	260,086	230
MCOM22T	22	50	20.00	28	25.84	1.5	38.10	15.0	315,216	280
MCOM25T	25	56	22.00	31	29.60	1.5	42.86	15.0	390,056	390
MCOM30T	30	66	25.00	37	34.81	1.5	50.80	17.0	525,360	610

**SELF-LUBRICATING**

# Related Products Overview



QA1 is one of the few companies that offers such a complete selection of complementary connection components. We offer a variety of sizes to fit any of your needs, and we supply products to a variety of markets, including agriculture, lawn and garden, construction, packaging, energy, medical equipment and fitness equipment, among others. QA1's quality system is ISO 9001 certified. We follow strict processes, use precision machinery and inspect all of our products to ensure the quality meets our high standards. This focus on quality has enabled us to achieve prominence in the supply of connection components to OEM contract manufacturers and various industrial and racing industries.

## BALL JOINTS

### INDUSTRIAL BALL JOINTS

QA1 offers two angled ball joints for various industrial markets: a staked design with a rubber grommet and a quick disconnect style. The staked design, which is commonly used in throttle and shifter linkages as well as various other linkages, features a rubber grommet that acts as a shield to keep out dirt and other contaminants. The quick disconnect style features a stud that comes out quickly for ease of disassembly and is designed for low-force mechanical linkages, including carburetor linkages and fuel injection applications. The staked design is offered in a carbon steel or stainless steel body, and the quick disconnect style is made of carbon steel with a stainless steel spring. All carbon steel styles are protective coated for corrosion resistance.

### RACING BALL JOINTS

QA1 offers ball joints in bolt-in, press-in and screw-in style ball joints for high-speed applications and extreme environments. Designed for motorsports racing markets, they are an ideal substitute for industrial applications needing strong, wear resistant ball joints. Their unique patented design includes self-lubricating components to ensure smooth operation and allows adjustability while they are installed.



## LINKAGE ADJUSTERS

QA1's linkage adjusters can be used in any situation where you might need a little extra adjustment in your rod end length. QA1 now offers both male-to-female adjusters and male-to-male adjusters to accommodate any need.

The male-to-female adjusters are available in both alloy steel and aluminum. The alloy steel adjusters are zinc plated and heat treated for superior strength, and the aluminum adjusters are manufactured from 7075-T6 high grade aluminum and black anodized.

QA1's male-to-male linkage adjusters are made from alloy steel and are zinc plated and yellow dichromate for superior strength. The male-to-male design includes left hand threads on one side and right hand threads on the other and provides use for an even greater variety of applications than ever before.



## LINKAGE RODS

When your connection needs more adjustment, QA1's linkage rods can provide it. Made from carbon steel and protective coated for corrosion resistance, they are available in a variety of sizes for numerous applications and come with left hand threads on one side and right hand threads on the other.



Related Products

## Related Products Overview

### CLEVISES

A clevis can be used to adjust your linkage mounting point. QA1's clevises are manufactured from carbon steel and are protective coated for corrosion resistance. Polished, hard chrome plated and aluminum clevises are also available, and all are available with left hand and right hand threads, so you can find one for almost any application.



### ROD EYES

A rod eye, also known as a solid rod end, is used when side-to-side misalignment is not required. QA1's rod eyes are available in carbon steel in right and left hand threads and are protective coated for corrosion resistance.



### SPACERS

Spacers are used in applications when mounting brackets are wider than the rod end ball width. Available in high misalignment or standard styles, QA1's spacers are made from high quality stainless steel in a variety of sizes for countless applications.



Standard spacers are used when the width of the ball is too narrow, while a high misalignment spacer is used when more articulation is needed in the rod end. The high misalignment spacers reduce the rod end bore size so an increased angle, or misalignment, is achieved.



Have questions about any of our products? Call our tech line at **1-800-721-7761** or visit **www.QA1.net** to learn more about our products.

### TUBE ADAPTERS

QA1's weld-in tube adapters are CNC machined to precise tolerances from special, easily weldable alloy steel. Available in a large assortment of sizes to fit most popular tubing, they are an effective way to adapt rod ends or rebuildable bearings to a variety of applications. QA1's tube adapters are available in both right and left hand threads, with the left hand units marked with a machined groove for easy identification.



They are also available with an integrated hex in select sizes; if those aren't for you, QA1 also has weld-on hexes sold separately that work perfectly with the standard tube adapters.



### WELD-ON WRENCH HEXES

Used to provide grip for easy adjustment, QA1's weld-on wrench hexes can be used with tube adapters in place of using a hex-style tube adapter. Simply take a smooth-style tube adapter and slip the weld-on wrench hex over the tube, then weld the hex to the tube on the desired area. With the weld-on hexes, you can place the hex onto the tube where it is most convenient for you and where it can provide easy adjustment.



### JAM NUTS

Jam nuts are usually half the width of a standard nut and are commonly jammed up against a standard nut to lock the two into place. QA1 offers both steel and aluminum jam nuts in a variety of sizes and in right and left hand threads. The steel units, which are now available in metric as well as inch units, are manufactured from protective coated carbon steel. The aluminum units are a clear anodized 7075 aluminum.



# Racing Ball Joints

Related  
Products

# QA1

Because QA1 racing ball joints are designed for high-speed, hard core racing applications, they are an ideal substitute for any application that deals with high speeds and extreme environments. Our patented design is available in three different housings (bolt-in, press-in, and screw-in styles) so that you can find a ball joint for any need. The diagram below highlights the main features of this product.

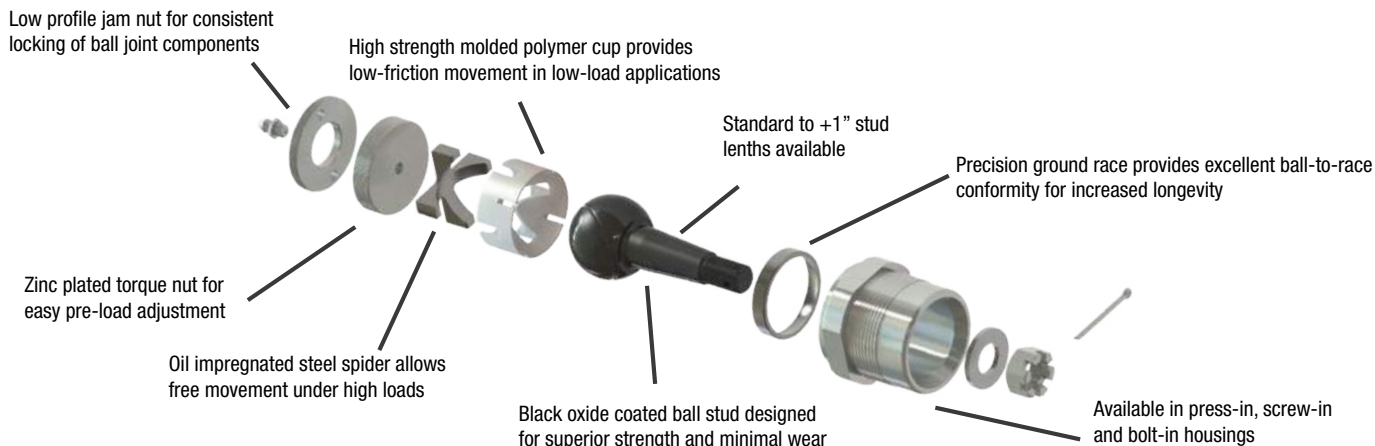

DIMENSIONS IN INCHES

## Screw-In Style

Part Number	Misalign. Angle a°	Under Shoulder Length C	Housing Depth B	Stud Length X	Stud Length Y	Shoulder OD D	Wrench Flat E	Thread Major Dia. F	Stud Taper K	Stud Thread L	Taper Major Dia. M	Housing OD N	Moog® Interchange
1210-105	64	1.25	1.840	2.33	3.542	2.110	1.912	1.837	1.5:12	1/2-20	0.724	1.811	K772
1210-200S	64	1.25	1.840	2.43	3.642	2.110	1.912	1.837	1.5:12	1/2-20	0.724	1.811	K772
1210-201S	64	1.25	1.840	2.83	4.042	2.110	1.912	1.837	1.5:12	1/2-20	0.724	1.811	K772
1210-238S	64	1.25	1.840	3.33	4.542	2.110	1.912	1.837	1.5:12	1/2-20	0.724	1.811	K772
1210-102	42	1.39	2.047	2.41	3.848	2.308	1.953	2.012	2:12	5/8-18	0.830	1.953	K6141T
1210-214S	42	1.39	2.047	2.51	3.948	2.308	1.953	2.012	2:12	5/8-18	0.830	1.953	K6141T
1210-215S	42	1.39	2.047	2.91	4.348	2.308	1.953	2.012	2:12	5/8-18	0.830	1.953	K6141T
1210-106	40	1.39	2.047	2.71	4.143	2.308	1.953	2.012	1.5:12	5/8-18	0.892	1.953	K727, MP1003
1210-216S	40	1.39	2.047	2.81	4.243	2.308	1.953	2.012	1.5:12	5/8-18	0.892	1.953	K727, MP1003
1210-217S	40	1.39	2.047	3.21	4.643	2.308	1.953	2.012	1.5:12	5/8-18	0.892	1.953	K727, MP1003
1210-107	64	1.25	1.840	2.66	3.871	2.110	1.912	1.837	1.5:12	5/8-18	0.780	1.811	K719
1210-206S	64	1.25	1.840	2.76	3.971	2.110	1.912	1.837	1.5:12	5/8-18	0.780	1.811	K719
1210-207S	64	1.25	1.840	3.16	4.371	2.110	1.912	1.837	1.5:12	5/8-18	0.780	1.811	K719
1210-111	68	1.25	1.840	2.59	3.803	2.110	1.912	1.837	1.5:12	9/16-18	0.711	1.811	MP1002
1210-212S	68	1.25	1.840	2.69	3.903	2.110	1.912	1.837	1.5:12	9/16-18	0.711	1.811	MP1002
1210-213S	68	1.25	1.840	3.09	4.303	2.110	1.912	1.837	1.5:12	9/16-18	0.711	1.811	MP1002

HARDCORE APPLICATIONS ONLY!  
**NOT FOR STREET USE.**

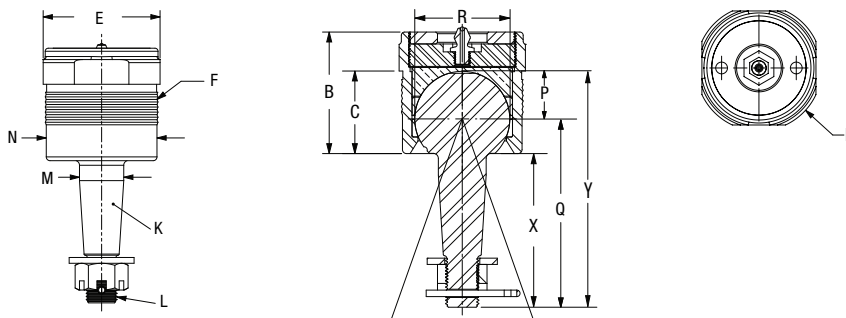

DIMENSIONS IN INCHES

### Bolt-In Style

Part Number	Misalign. Angle $a^\circ$	Under Shoulder Length C	Housing Depth B	Stud Length X	Stud Length Y	Bolt Pattern Y Dim. G	Bolt Pattern X1 Dim. H	Bolt Pattern X2 Dim. I	Stud Taper K	Stud Thread L	Taper Major Dia. M	Housing OD N	Moog® Interchange
1210-101	65	0.619	1.819	2.330	3.542	1.062	1.875	2.813	1.5:12	1/2-20	0.724	1.818	K6024
1210-200B	65	0.619	1.819	2.430	3.642	1.062	1.875	2.813	1.5:12	1/2-20	0.724	1.818	K6024
1210-201B	65	0.619	1.819	2.830	4.042	1.062	1.875	2.813	1.5:12	1/2-20	0.724	1.818	K6024
1210-238B	65	0.619	1.819	3.330	4.542	1.062	1.875	2.813	1.5:12	1/2-20	0.724	1.818	K6024
1210-103	65	0.619	1.819	2.641	3.850	1.062	1.875	2.813	2:12	1/2-20	0.723	1.818	K6136
1210-202B	65	0.619	1.819	2.741	3.950	1.062	1.875	2.813	2:12	1/2-20	0.723	1.818	K6136
1210-203B	65	0.619	1.819	3.141	4.350	1.062	1.875	2.813	2:12	1/2-20	0.723	1.818	K6136
1210-104	73	1.110	1.820	2.380	3.593	0.911	1.750	2.500	2:12	1/2-20	0.635	1.816	K5208
1210-204B	73	1.110	1.820	2.480	3.693	0.911	1.750	2.500	2:12	1/2-20	0.635	1.816	K5208
1210-205B	73	1.110	1.820	2.880	4.093	0.911	1.750	2.500	2:12	1/2-20	0.635	1.816	K5208
1210-285B	73	1.110	1.820	3.380	4.593	0.911	1.750	2.500	2:12	1/2-20	0.724	1.816	K5208
1210-113	73	1.110	1.820	2.270	3.486	0.807	1.770	2.402	1.5:12	1/2-20	0.635	1.816	K5108

HARDCORE APPLICATIONS ONLY!  
NOT FOR STREET USE.

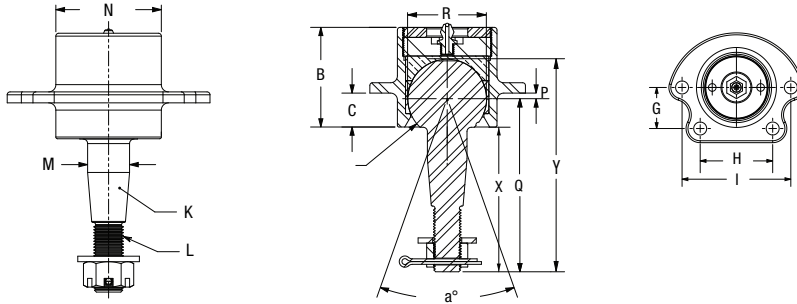

DIMENSIONS IN INCHES

### Press-In Style

Part Number	Misalign. Angle $a^\circ$	Under Shoulder Length C	Housing Depth B	Stud Length X	Stud Length Y	Shoulder OD D	Press-In Major Dia. J	Stud Taper K	Stud Thread L	Taper Major Dia. M	Housing OD N	Moog® Interchange
1210-108	44	1.060	2.000	3.230	4.625	2.250	1.976	2:12	5/8-18	0.872	2.000	K6117T
1210-218P	44	1.060	2.000	3.330	4.725	2.250	1.976	2:12	5/8-18	0.872	2.000	K6117T
1210-219P	44	1.060	2.000	3.730	5.125	2.250	1.976	2:12	5/8-18	0.872	2.000	K6117T
1210-109	64	1.060	1.830	2.440	3.641	2.250	2.092	2:12	1/2-20	0.784	2.000	K6145T
1210-208P	64	1.060	1.830	2.540	3.741	2.250	2.092	2:12	1/2-20	0.784	2.000	K6145T
1210-209P	64	1.060	1.830	2.940	4.141	2.250	2.092	2:12	1/2-20	0.784	2.000	K6145T
1210-110	64	1.125	1.830	2.190	3.396	2.300	2.008	1.5:12	1/2-20	0.785	2.000	K5103
1210-210P	64	1.125	1.830	2.290	3.496	2.300	2.008	1.5:12	1/2-20	0.785	2.000	K5103
1210-211P	64	1.125	1.830	2.690	3.896	2.300	2.008	1.5:12	1/2-20	0.785	2.000	K5103
1210-112	42	1.130	2.047	2.410	3.848	2.375	2.185	2:12	5/8-18	0.830	1.811	K6141
1210-214P	42	1.130	2.047	2.510	3.948	2.375	2.185	2:12	5/8-18	0.830	1.811	K6141
1210-215P	42	1.130	2.047	2.910	4.348	2.375	2.185	2:12	5/8-18	0.830	1.811	K6141

HARDCORE APPLICATIONS ONLY!  
NOT FOR STREET USE.

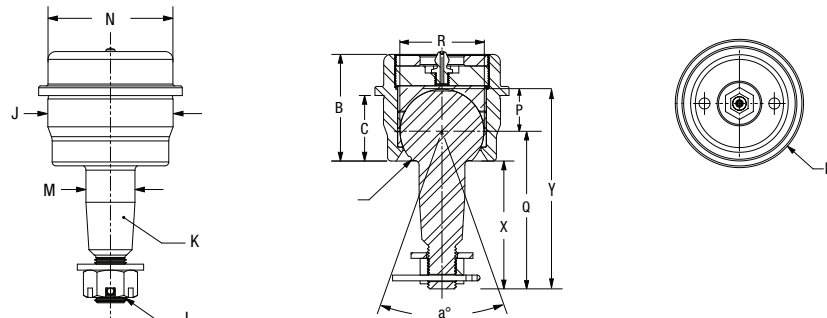

# Industrial Ball Joints

Related Products



## Staked Design Ball Joint with Rubber Grommet Features

- CARBON STEEL STAKED DESIGN BALL JOINTS
- Carbon Steel Body & Ball Stud
  - Protective Coated for Corrosion Resistance

- STAINLESS STEEL STAKED DESIGN BALL JOINTS
- Stainless Steel Ball Stud
  - Stainless Steel Body

PART NUMBER		DIMENSIONS IN INCHES																	
Carbon Steel Ball Joints	Right Hand	Left Hand	A Thread UNF-2B	B ± .020	C ± .020	D Min.	E ± .020	F ± .020	G Ref.	H Ref.	J + .002 - .010	K Ref.	L Ref.	M UNF-2A	N Ref.	WF + .002 - .010	WF2 ± .020	Tensile & Shear Strength	Force to Remove (Lbs.)
	BJGR3	BJGL3	10-32	1.063	.875	.438	.438	.438	.125	.062	.312	.177	.375	10-32	.125	.312	.250	295	690
BJGR4	BJGL4	1/4-28	1.219	.969	.500	.469	.562	.125	.094	.375	.193	.437	1/4-28	.125	.375	.281	862	1,005	
BJGR5	BJGL5	5/16-24	1.406	1.125	.562	.531	.687	.156	.094	.437	.232	.500	5/16-24	.188	.437	.281	1,587	1,282	
BJGR6	BJGL6	3/8-24	1.687	1.375	.750	.687	.875	.187	.094	.500	.287	.625	3/8-24	.188	.500	.312	2,437	1,700	
BJGR7	BJGL7	7/16-20	2.375	1.937	1.000	.875	1.125	.250	.125	.625	.412	.750	7/16-20	.250	.625	.375	3,390	2,700	
BJGR8	BJGL8	1/2-20	2.375	1.937	1.000	.875	1.125	.250	.125	.625	.412	.750	1/2-20	.250	.625	.375	3,390	2,700	

PART NUMBER		DIMENSIONS IN INCHES																	
Stainless Steel Ball Joints	Right Hand	Left Hand	A Thread UNF-2B	B ± .020	C ± .020	D Min.	E ± .020	F ± .020	G Ref.	H Ref.	J + .002 - .010	K Ref.	L Ref.	M UNF-2A	N Ref.	WF + .002 - .010	WF2 ± .020	Tensile & Shear Strength	Force to Remove (Lbs.)
	BJGR3H	BJGL3H	10-32	1.063	.875	.438	.438	.438	.125	.062	.312	.177	.375	10-32	.125	.312	.250	265	690
BJGR4H	BJGL4H	1/4-28	1.219	.969	.500	.469	.562	.125	.094	.375	.193	.437	1/4-28	.125	.375	.281	440	1,005	
BJGR5H	BJGL5H	5/16-24	1.406	1.125	.562	.531	.687	.156	.094	.437	.232	.500	5/16-24	.188	.437	.281	635	1,282	
BJGR6H	BJGL6H	3/8-24	1.687	1.375	.750	.687	.875	.187	.094	.500	.287	.625	3/8-24	.188	.500	.312	970	1,700	
BJGR8H	BJGL8H	1/2-20	2.375	1.937	1.000	.875	1.125	.250	.125	.625	.412	.750	1/2-20	.250	.625	.375	2,000	2,700	

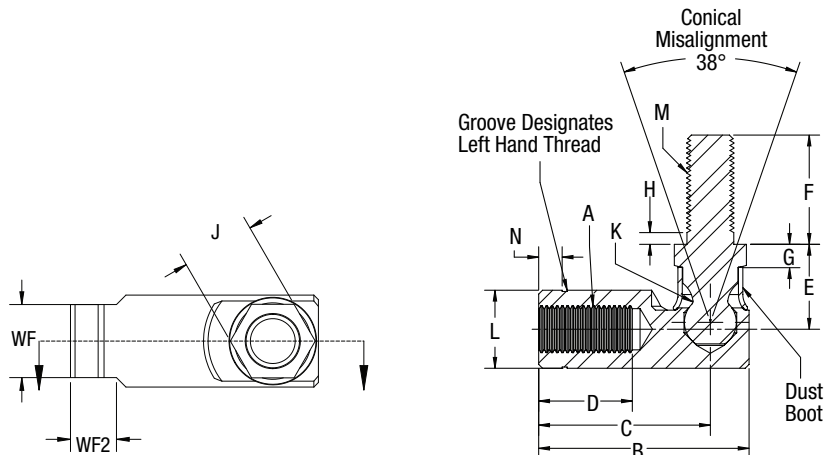



### Quick Disconnect Ball Joint Features

#### BALL STUD

- Carbon Steel
- Protective Coated for Corrosion Resistance

#### BODY

- Carbon Steel
- Protective Coated for Corrosion Resistance

#### SLEEVE

- Carbon Steel
- Protective Coated for Corrosion Resistance

#### SPRING

- Stainless Steel

#### PART NUMBER

#### DIMENSIONS IN INCHES

### Quick Disconnect Ball Joints

Right Hand	Left Hand	A Thread UNF-2B	B ± .020	C ± .020	D Min.	E ± .020	F ± .020	G Min.	H Max.	J + .002 - .010	K Ref.	L ± .010	M Ref.	Tensile & Shear Strength	Force to Remove (Lbs.)
<b>BJDR3</b>	<b>BJDL3</b>	10-32	1.094	.906	.437	.437	.437	.125	.062	.312	.171	.312	.500	450	650
<b>BJDR4</b>	<b>BJDL4</b>	1/4-28	1.094	.906	.531	.469	.562	.125	.062	.312	.171	.312	.500	500	650
<b>BJDR5</b>	<b>BJDL5</b>	5/16-24	1.563	1.125	.563	.594	.689	.156	.094	.437	.232	.438	.680	1,000	1,000
<b>BJDR6</b>	<b>BJDL6</b>	3/8-24	1.940	1.563	.750	.719	.875	.188	.094	.500	.287	.562	.820	1,250	1,250

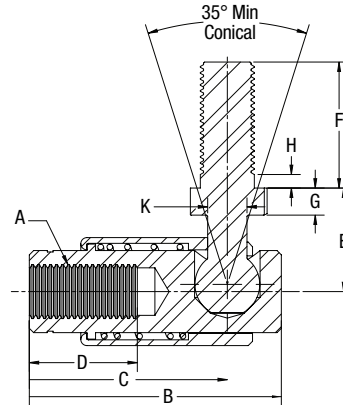
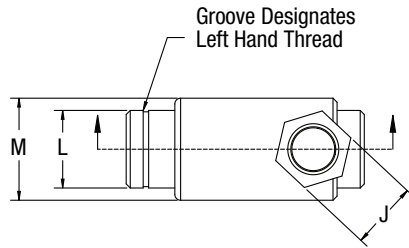

Have questions about any of our products? Call our tech line at **1-800-721-7761** or visit **www.QA1.net** to learn more about our products.

# Industrial Linkage Rods

Related Products



## Linkage Rod Features

- BODY**
- Carbon Steel and 300 Series Stainless Steel
  - Protective Coated for Corrosion Resistance

## Carbon Steel Linkage Rods

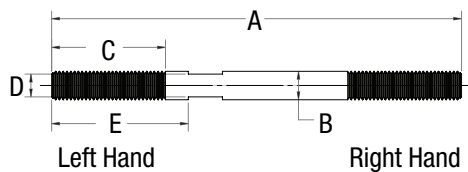

PART NUMBER DIMENSIONS IN INCHES

	A ±.030	B ± .010	C +.060 -.030	D +.003 -.012	E ± .030	Thread UNF-3A
1698-114	7.00	.25	1.125	.218	1.5	1/4-28
1698-115	7.50	.25	1.125	.218	1.5	1/4-28
1698-120	20.00	.25	1.125	.218	1.5	1/4-28
1698-116	21.00	.25	1.125	.218	1.5	1/4-28
1698-117	4.50	.312	1.250	.250	1.5	5/16-24
1698-124	6.00	.312	1.250	.250	1.5	5/16-24
1698-125	9.00	.312	1.250	.250	1.5	5/16-24
1698-122	5.50	.375	1.375	.344	1.5	3/8-24
1698-118	9.00	.375	1.375	.344	1.5	3/8-24
1698-121	13.50	.375	1.375	.344	1.5	3/8-24
1698-119	20.25	.375	1.375	.344	1.5	3/8-24
1698-123	13.00	.500	1.625	.438	1.75	1/2-20
1698-128	4.00	.312	1.250	.250	1.5	5/16-24
1698-129	8.50	.312	1.250	.250	1.5	5/16-24
1698-130	16.00	.312	1.250	.250	1.5	5/16-24
1698-151	5.50	.312	2.365	.250	2.5	5/16-24
1698-152	16.00	.500	3.250	.438	3.375	1/2-20

**NEW PRODUCT**

## 300 Series Stainless Steel Linkage Rods

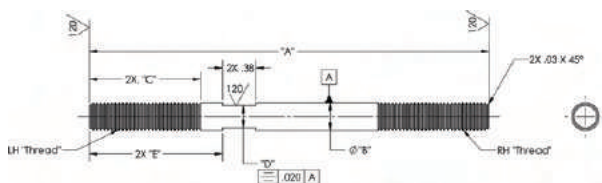

PART NUMBER DIMENSIONS IN INCHES

	A ±.030	B ± .010	C +.060 -.030	D +.003 -.012	E ± .030	Thread UNF-3A
1698-131	4.00	.312	1.250	.250	1.5	5/16-24
1698-132	5.50	.312	1.250	.250	1.5	5/16-24
1698-133	7.75	.312	1.250	.250	1.5	5/16-24
1698-134	8.50	.312	1.250	.250	1.5	5/16-24
1698-135	14.75	.312	1.250	.250	1.5	5/16-24

Related Products

### Male-to-Male Linkage Adjuster Features

- BODY**
- Alloy Steel
  - Heat Treated
  - Protective Coated

### Male-to-Male Linkage Adjusters

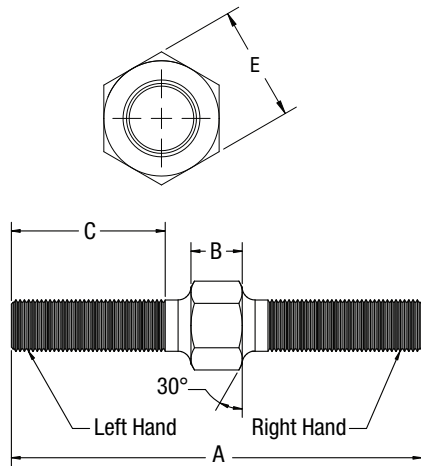

**PART NUMBER**

**DIMENSIONS IN INCHES**

Alloy Steel	Thread UNF-3A Left Hand	Thread UNF-3A Right Hand	A ± .020	B ± .020	C + .062 - .031	E + .000 - .015
ASM3-19	10-32	10-32	1.9400	0.1900	0.7500	0.3750
ASM6-33	3/8-24	3/8-24	3.2500	0.3750	1.2500	0.5625
ASM7-37	7/16-20	7/16-20	3.6875	0.4375	1.3750	0.6880
ASM12-60	3/4-16	3/4-16	6.0000	0.7500	2.2500	1.1250
ASM12-65	3/4-16	3/4-16	6.5000	1.2500	2.2500	1.1250
ASM12-75	3/4-16	3/4-16	7.5000	2.2500	2.2500	1.1250
ASM14-66	7/8-14	7/8-14	6.6250	0.8750	2.3750	1.3125
ASM16-80	1 1/4-12	1 1/4-12	8.0000	1.0000	2.8750	1.8750
ASM16-1-80	1-14**	1-14**	8.0000	1.0000	2.8750	1.5000
ASM16-2-80	1-12	1-12	8.0000	1.0000	2.8750	1.5000

### Male-to-Female Linkage Adjuster Features

- STEEL ADJUSTERS**
- Alloy Steel
  - Heat Treated
  - Zinc Plated & Yellow Dichromate

- ALUMINUM ADJUSTERS**
- 7075-T6 Aluminum
  - Black Anodized

### Male-to-Female Linkage Adjusters

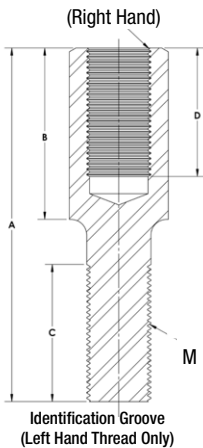

**PART NUMBER**

**DIMENSIONS IN INCHES**

Alloy Steel	Aluminum	M UNF-3A Left Hand	F UNF-2B Right Hand	A Ref.	B ± .020	C + .062 - .031	D + .062 - .031	E Ref.
AS6-6	AA6-6	3/8-24	3/8-24	2.875	1.250	1.250	0.812	9/16
AS7-7	AA7-7	7/16-20	7/16-20	3.125	1.375	1.375	0.937	11/16
AS8-8	AA8-8	1/2-20	1/2-20	3.375	1.500	1.500	1.062	3/4
AS10-10	AA10-10	5/8-18	5/8-18	3.813	1.813	1.625	1.375	15/16
AS12-12	AA12-12	3/4-16	3/4-16	4.125	2.000	1.750	1.562	1 1/8
ADJ12-12*	-	3/4-16	3/4-16	4.125	2.000	1.600	1.531	1

# Clevises & Rod Eyes

Related  
Products

# QA1

## Clevis Features

### STANDARD CLEVIS

- Carbon Steel
- Protective Coated for Corrosion Resistance

## Clevises

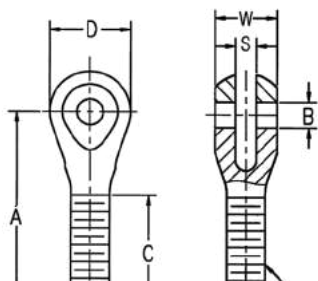

### PART NUMBER

### DIMENSIONS IN INCHES

Right Hand	Left Hand	Bore x Thread Ref.	B + .005 - .000	D ± .010	W ± .005	A ± .015	C + .062 - .031	S ± .005	Thread Ref.
CR4-5	CL4-5	1/4 X 5/16	0.2500	0.875	0.625	2.250	1.250	0.1880	5/16-24
CR5-5	CL5-5	5/16 X 5/16	0.3125	0.875	0.625	2.250	1.250	0.1880	5/16-24
CR5-6	CL5-6	5/16 X 3/8	0.3125	0.875	0.625	2.250	1.250	0.1880	3/8-24
CR5-8	CL5-8	5/16 X 1/2	0.3125	1.000	0.750	2.500	1.500	0.2500	1/2-20
CR6-8	CL6-8	3/8 X 1/2	0.3750	1.000	0.750	2.500	1.500	0.2500	1/2-20
CR6-8-1CP*	CL6-8-1CP*	3/8 X 1/2	0.3750	1.000	0.750	2.750	1.500	0.3125	1/2-20
CR6-8-2CP*	CL6-8-2CP*	3/8 X 1/2	0.3750	1.000	0.750	2.750	1.500	0.3750	1/2-20
CR6-10	CL6-10	3/8 X 5/8	0.3750	1.125	0.825	3.375	2.000	0.3750	5/8-18
CR6-10CP*	-	3/8 X 5/8	0.3750	1.125	0.825	3.375	2.000	0.3750	5/8-18
CR6-12	CL6-12	3/8 X 3/4	0.3750	1.125	0.825	3.375	2.000	0.3750	3/4-16
CR7-8	CL7-8	7/16 X 1/2	0.4375	1.125	0.825	3.375	2.000	0.3750	1/2-20
CR7-10	CL7-10	7/16 X 5/8	0.4375	1.125	0.825	3.375	2.000	0.3750	5/8-18
CR8-10	CL8-10	1/2 X 5/8	0.5000	1.125	0.825	3.375	2.000	0.3750	5/8-18
CR8-12AL**	CL8-12AL**	1/2 X 3/4	0.5000	1.125	0.825	3.375	2.000	0.2500	3/4-16
CR8-12-1	CL8-12-1	1/2 X 3/4	0.5000	1.125	0.825	3.375	2.000	0.3750	3/4-16

## Rod Eye Features

### STANDARD ROD EYE

- Carbon Steel
- Protective Coated for Corrosion Resistance

## Rod Eyes

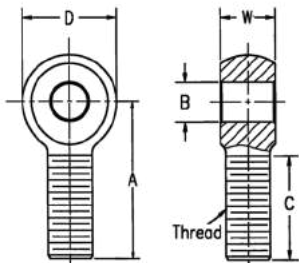

### PART NUMBER

### DIMENSIONS IN INCHES

Right Hand	Left Hand	Bore x Thread + .005 - .000	B ± .010	D ± .010	W ± .005	A ± .015	C + .062 - .031	Thread Ref.
RER8	-	1/2 X 1/2	0.500	1.312	0.625	2.437	1.500	1/2-20
RER8-12	-	1/2 X 3/4	0.500	1.500	0.875	2.875	1.750	3/4-16
RER10	-	5/8 X 5/8	0.625	1.500	0.750	2.625	1.625	5/8-18
RER10-12*	-	5/8 X 3/4	0.625	1.500	0.875	2.500	1.650	3/4-16
RER10-12-1	REL10-12-1	5/8 X 3/4	0.625	1.750	0.875	2.875	1.750	3/4-16
RER12	-	3/4 X 3/4	0.750	1.750	0.875	2.875	1.750	3/4-16

### Spacer Features

- Stainless Steel

DIMENSIONS IN INCHES

### Standard Spacers

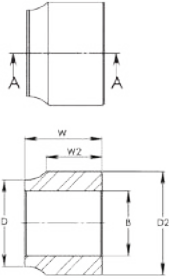

Part Number	D + .000 - .010	D2 Ref.	B + .003 - .000	W ± .100	W2 Ref.	Mating Rod End Bore
SG84	0.698	0.875	0.500	0.250	0.034	0.500
SG85	0.698	0.875	0.500	0.313	0.097	0.500
SG88	0.698	0.875	0.500	0.500	0.284	0.500
SG812	0.698	0.875	0.500	0.750	0.534	0.500
SG104	0.839	1.000	0.625	0.250	0.041	0.625
SG105	0.839	1.000	0.625	0.313	0.104	0.625
SG108	0.839	1.000	0.625	0.500	0.291	0.625
SG124	0.978	1.125	0.750	0.250	0.048	0.750
SG128	0.978	1.125	0.750	0.500	0.298	0.750
SG1212	0.978	1.125	0.750	0.750	0.548	0.750

DIMENSIONS IN INCHES

### High Misalignment Spacers

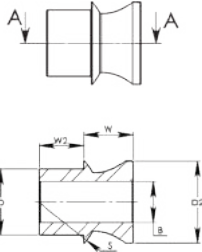

Part Number	D + .000 - .001	D2 ± .005	B + .003 - .000	W ± .005	W2 ± .005	S Ref.	Misalign. Angle a°	Total Installed Width Ref.	Mating Rod End Bore
SG10-84	0.624	0.825	0.500	0.250	0.360	1.125	54	1.250	0.625
SG12-84	0.749	0.850	0.500	0.250	0.423	1.312	56	1.375	0.750
SG12-88	0.749	0.850	0.500	0.500	0.423	1.312	58	1.875	0.750
SG12-108	0.749	0.950	0.625	0.500	0.423	1.312	52	1.875	0.750
SG14-813	0.874	1.000	0.500	0.813	0.423	1.375	52	2.500	0.875
SG14-1012	0.874	1.000	0.625	0.775	0.423	1.375	46	2.425	0.875
SG16-1210	0.999	1.250	0.750	0.625	0.673	1.875	60	2.625	1.375
SG16-1212	0.999	1.250	0.750	0.750	0.673	1.875	57	2.875	1.000

Part Number	D	D2	B	W	W2	S	Misalign. Angle a°	Total Installed Width Ref.	Mating Rod End Bore
SN6-45	0.375	0.500	0.250	0.297	0.195	0.656	54	1.000	0.406
SN8-66	0.499	0.625	0.375	0.375	0.242	0.781	56	1.250	0.500
SN8-68	0.499	0.625	0.375	0.500	0.242	0.781	57	1.500	0.500
SN10-87	0.624	0.830	0.500	0.438	0.301	0.968	48	1.500	0.625
SN12-68	0.749	0.875	0.375	0.500	0.360	1.187	62	1.750	0.750
SN12-88	0.749	0.950	0.500	0.500	0.360	1.187	56	1.750	0.750
SN12-98	0.749	0.950	0.563	0.500	0.360	1.187	54	1.750	0.750
SN12-107	0.749	0.950	0.625	0.438	0.360	1.187	50	1.625	0.750
SN14-89	0.874	0.950	0.500	0.563	0.423	1.312	52	2.000	0.875
SN16-913	0.999	1.250	0.563	0.813	0.485	1.500	52	2.625	1.000
SN16-1013	0.999	1.250	0.625	0.813	0.485	1.500	50	2.625	1.000
SN20-1014-H	1.249	1.313	0.625	0.908	0.579	2.000	68	3.000	1.188
SN20-1211-H	1.249	1.313	0.750	0.719	0.579	2.000	64	2.625	1.188
SN24-1017-H	1.499	1.625	0.625	1.063	0.673	2.312	68	3.500	1.375
SN24-1221-H	1.499	1.625	0.750	1.313	0.673	2.312	65	4.000	1.375

High Misalignment Standard Ball Width Spacers (SG Series) will fit WPB-T (size 14 & 16 only), AIB, SIB and MIB spherical bearings and all inch rod ends.

High Misalignment Narrow Ball Width Spacers (SN Series), will fit COM, COM-SS and NPB spherical bearings. SN-H Series will fit H-COM spherical bearings only.

# Tube Adapters

Related  
Products



## Tube Adapter Features

- Weldable Alloy Steel
- Smooth or Hex Styles

DIMENSIONS IN INCHES

### Tube Adapters

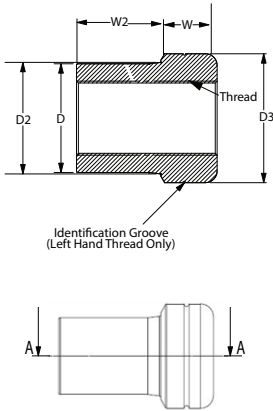

Part Number	Right Hand Left Hand	Style	Tubing O.D.	Tubing Wall Thickness	Thread UNF-2B	D ± .005	D2 ± .005	D3 ± .005	W ± .010	W2 ± .010
1844-101	RH	Smooth	3/8	0.058	10-32	0.234	0.264	0.375	0.30	0.45
1844-103	RH	Smooth	1/2	0.058	1/4-28	0.359	0.389	0.500	0.40	0.60
1844-106	RH	Smooth	5/8	0.058	5/16-24	0.484	0.514	0.625	0.50	0.75
1844-108	RH	Smooth	5/8	0.058	3/8-24	0.484	0.514	0.625	0.50	0.75
1844-105	LH	Smooth	5/8	0.058	5/16-24	0.484	0.514	0.625	0.50	0.75
1844-109	RH	Smooth	3/4	0.058	3/8-24	0.609	0.639	0.750	0.50	0.75
1844-111	RH	Smooth	3/4	0.058	7/16-20	0.609	0.639	0.750	0.55	0.83
1844-113	RH	Smooth	3/4	0.065	3/8-24	0.595	0.625	0.750	0.50	0.75
1844-110	LH	Smooth	3/4	0.058	7/16-20	0.609	0.639	0.750	0.55	0.83
1844-112	LH	Smooth	3/4	0.065	3/8-24	0.595	0.625	0.750	0.50	0.75
1845-101	LH	Hex	3/4	0.058	3/8-24	0.609	0.639	0.750	0.50	0.75
1844-114	RH	Smooth	7/8	0.058	3/8-24	0.734	0.764	0.875	0.50	0.75
1844-115	RH	Smooth	7/8	0.058	7/16-20	0.734	0.764	0.875	0.55	0.83
1844-117	RH	Smooth	7/8	0.065	1/2-20	0.720	0.750	0.875	0.60	0.90
1844-116	LH	Smooth	7/8	0.065	1/2-20	0.720	0.750	0.875	0.60	0.90
1844-155	RH	Smooth	7/8	0.065	3/8-24	0.720	0.750	0.875	0.50	0.75
1844-156	LH	Smooth	7/8	0.065	3/8-24	0.720	0.750	0.875	0.50	0.75
1845-102	LH	Hex	7/8	0.058	3/8-24	0.734	0.764	0.875	0.50	0.75
1844-118	RH	Smooth	1	0.058	1/2-20	0.859	0.889	1.000	0.60	0.90
1844-120	RH	Smooth	1	0.120	1/2-20	0.735	0.765	1.000	0.60	0.90
1844-122	RH	Smooth	1	0.120	5/8-18	0.735	0.765	1.000	0.65	0.98
1844-119	LH	Smooth	1	0.120	1/2-20	0.735	0.765	1.000	0.60	0.90
1844-121	LH	Smooth	1	0.120	5/8-18	0.735	0.765	1.000	0.65	0.98
1845-103	LH	Hex	1	0.058	1/2-20	0.859	0.889	1.000	0.60	0.90
1844-126	RH	Smooth	1 1/8	0.095	5/8-18	0.910	0.940	1.125	0.65	0.98
1844-125	LH	Smooth	1 1/8	0.095	5/8-18	0.910	0.940	1.125	0.65	0.98
1844-127	RH	Smooth	1 1/4	0.095	3/4-16	1.035	1.065	1.250	0.70	1.05
1844-128	RH	Smooth	1 1/4	0.120	3/4-16	0.985	1.015	1.250	0.70	1.05
1844-153	RH	Smooth	1 1/4	0.120	5/8-18	0.985	1.015	1.250	0.65	0.98
1844-154	LH	Smooth	1 1/4	0.120	5/8-18	0.985	1.015	1.250	0.65	0.98
1844-130	RH	Smooth	1 1/4	0.120	7/8-14	0.985	1.015	1.250	0.80	1.20
1844-132	RH	Smooth	1 1/4	0.120	7/8-18	0.985	1.015	1.250	0.80	1.20
1844-131	LH	Smooth	1 1/4	0.120	7/8-18	0.985	1.015	1.250	0.80	1.20
1845-104	LH	Hex	1 1/4	0.095	3/4-16	1.035	1.065	1.250	0.70	1.05
1845-105	LH	Hex	1 1/4	0.120	3/4-16	0.985	1.015	1.250	0.70	1.05
1844-133	RH	Smooth	1 3/8	0.095	3/4-16	1.160	1.190	1.375	0.70	1.05
1845-106	LH	Hex	1 3/8	0.095	3/4-16	1.160	1.190	1.375	0.70	1.05
1844-135	RH	Smooth	1 1/2	0.120	1-14	1.235	1.265	1.500	0.85	1.28
1844-137	RH	Smooth	1 1/2	0.250	5/8-18	0.975	1.005	1.500	0.65	0.98
1844-139	RH	Smooth	1 1/2	0.250	3/4-16	0.975	1.005	1.500	0.70	1.05
1844-138	LH	Smooth	1 1/2	0.250	3/4-16	0.975	1.005	1.500	0.70	1.05
1844-141	RH	Smooth	1 3/4	0.120	1 1/4-12	1.485	1.515	1.750	0.85	1.28
1844-143	RH	Smooth	1 3/4	0.250	7/8-14	1.225	1.255	1.750	0.80	1.20
1844-140	LH	Smooth	1 3/4	0.120	1 1/4-12	1.485	1.515	1.750	0.85	1.28
1844-142	LH	Smooth	1 3/4	0.250	7/8-14	1.225	1.255	1.750	0.80	1.20
1844-145	RH	Smooth	2	0.250	1-12	1.475	1.505	2.000	0.85	1.28
1844-147	RH	Smooth	2	0.250	1 1/4-12	1.475	1.505	2.000	0.85	1.28
1844-144	LH	Smooth	2	0.250	1-12	1.475	1.505	2.000	0.85	1.28
1844-146	LH	Smooth	2	0.250	1 1/4-12	1.475	1.505	2.000	0.85	1.28

Related Products

# Weld-On Wrench Hexes & Jam Nuts

### Weld-On Wrench Hex Features

- STANDARD WELD-ON WRENCH HEX
- Fits several O.D. tube dimensions

DIMENSIONS IN INCHES

### Weld-On Wrench Hexes

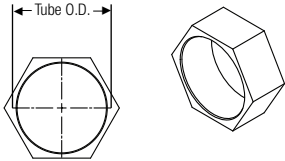

Part Number	Fits Tubing O.D. Size	Wrench Size
1865-101	3/8	5/8
1865-104	3/4	1
1865-108	1 1/4	1 1/2
1865-109	1 3/8	1 5/8
1865-111	1 5/8	1 7/8
1865-112	1 3/4	2
1865-113	2	2 1/4

### Jam Nut Features

- STEEL JAM NUTS
- High Carbon Steel
  - Chrome Plated
  - Reference ANSI B18.2.2-1972
  - Available in Inch and Metric

- ALUMINUM JAM NUTS
- 7075-T6 Aluminum
  - Clear Anodized

### Steel Jam Nuts

PART NUMBER			DIMENSIONS IN INCHES		
Right Hand	Left Hand	Threads UNF-2B	H Hex	W Width	
JNR3S	JNL3S	10-32	3/8	0.139	
JNR4S	JNL4S	1/4-28	7/16	0.163	
JNR5S	JNL5S	5/16-24	1/2	0.195	
JNR6S	JNL6S	3/8-24	9/16	0.227	
JNR7S	JNL7S	7/16-20	11/16	0.260	
JNR8S	JNL8S	1/2-20	3/4	0.323	
JNR10S	JNL10S	5/8-18	15/16	0.387	
JNR12S	JNL12S	3/4-16	1 1/8	0.425	
JNR14S	JNL14S	7/8-14	1 5/16	0.484	
JNR16S	JNL16S	1 1/4-12	1 7/8	0.719	
JNR16S-1	JNL16S-1	1-14	1 1/2	0.575	
JNR16S-2	JNL16S-2	1-12	1 7/8	0.575	

PART NUMBER			DIMENSIONS IN MILLIMETERS		
Right Hand	Left Hand	Threads 6H	H Hex	W Width	
MJNR5S	MJNL5S	M5 X 0.8	8.00	2.70	
MJNR6S	MJNL6S	M6 X 1.0	10.00	3.20	
MJNR8S	MJNL8S	M8 X 1.25	13.00	4.00	
MJNR8S-1	MJNL8S-1	M8 X 1.0	13.00	4.00	
MJNR10S	MJNL10S	M10 X 1.5	17.00	5.00	
MJNR10S-1	MJNL10S-1	M10 X 1.25	17.00	5.00	
MJNR12S	MJNL12S	M12 X 1.75	19.00	6.00	
MJNR12S-1	MJNL12S-1	M12 X 1.25	19.00	6.00	
MJNR14S	MJNL14S	M14 X 2.0	22.00	7.00	
MJNR14S-1	MJNL14S-1	M14 X 1.5	22.00	7.00	
MJNR16S	MJNL16S	M16 X 2.0	24.00	8.00	
MJNR16S-1	MJNL16S-1	M16 X 1.5	24.00	8.00	
MJNR20S	MJNL20S	M20 X 1.5	30.00	10.00	
MJNR20S-1	MJNL20S-1	M20 X 2.5	30.00	10.00	

### Aluminum Jam Nuts

PART NUMBER			DIMENSIONS IN INCHES		
Right Hand	Left Hand	Threads UNF-2B	H Hex	W Width	
JNR4A	JNL4A	1/4-28	7/16	0.163	
JNR5A	JNL5A	5/16-24	1/2	0.195	
JNR6A	JNL6A	3/8-24	9/16	0.227	
JNR7A	JNL7A	7/16-20	11/16	0.260	
JNR10A	JNL10A	5/8-18	15/16	0.387	
JNR12A	JNL12A	3/4-16	1 1/8	0.425	

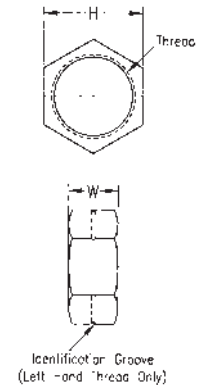

# Rod End Stud & Grease Fitting Configurations & Installation of Spherical Bearings

Related Products

# QA1

## Rod End Stud Configuration

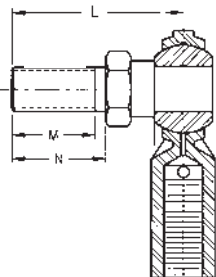

### DIMENSIONS IN INCHES

Rod End Bore Size	L Ref.	N ± .010	M Ref.	Thread UNF-2A
3/16	1.000	0.500	0.437	10-32
1/4	1.031	0.562	0.500	1/4-28
5/16	1.219	0.687	0.593	5/16-24
3/8	1.562	0.906	0.812	3/8-24
7/16	1.750	1.062	0.937	7/16-20
1/2	2.000	1.125	1.000	1/2-20
5/8	2.500	1.500	1.375	5/8-18
3/4	3.000	1.812	1.625	3/4-16

### DIMENSIONS IN MILLIMETERS

Rod End Bore Size	L Ref.	N ± .013	M Min.	Thread UNF-2A
5	22.00	13.00	10.0	M5 x 0.8
6	24.00	14.00	11.0	M6 x 1.0
8	29.50	17.50	14.0	M8 x 1.25
10	39.50	23.00	19.5	M10 x 1.5
12	48.00	28.50	24.5	M12 x 1.75
14	53.50	33.00	29.0	M14 x 2.0
16	64.00	38.00	34.0	M16 x 2.0

When ordering a standard stud, add the letter "S" to the completed rod end number. **Example: CMR8S**

If a studded rod end is ordered with a grease fitting, the standard placement is in the right hand location with stud pointed toward the viewer. Please specify if alternate placement is required.

When ordering a stud and grease fitting, add the letter "S" and "Z" to the completed number. **Example: CMR8SZ**

Studs available in carbon and stainless steel.

## Rod End Grease Fitting Configuration

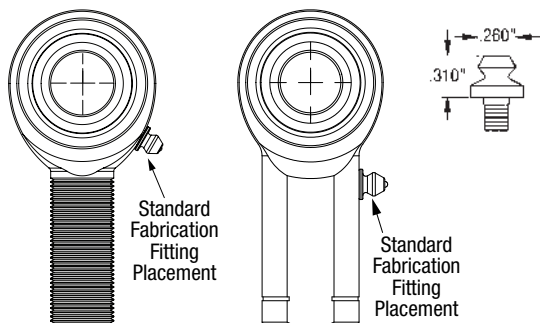

Standard grease fitting locations are illustrated at the left. Note that for a female configuration, once the male threaded component is fully engaged, the grease is forced through the hole at the top of the female shank to facilitate ball lubrication.

Order by adding the letter "Z" to the completed number. **Example: CMR8Z**

## Installation of Spherical Bearings

Proper press-fitting of spherical bearings into a housing fixture will result not only in smooth bearing performance, but also in better wear characteristics leading to longer life. QA1 engineering recommends strict adherence to the following installation procedures in order to assure optimal spherical bearing performance and wear.

The use of a hydraulic press to apply constant pressure is recommended. Any other shock-inducing device such as a hammer will result in damage and/or ultimate misfit. An installation tool, such as the one shown to the right, is ideal. Here the guide pin aligns the ball's bore parallel to the race O.D., while all force is applied to the outer race surface only. A lead chamfer (inset) on the bearing and/or housing fixture is essential.

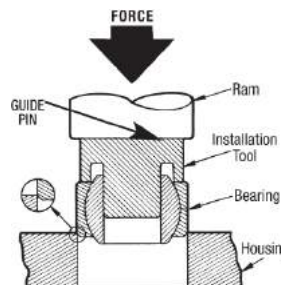

Technical Information



## Radial Static Load Ratings

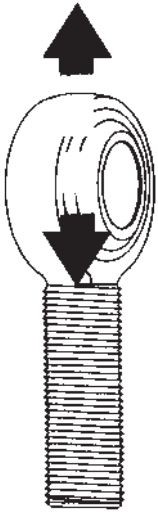

The ultimate radial static load rating is measured as the failure point when a load is increasingly applied to a pin inserted through the rod end's bore and pulled straight up while the rod end is fixtured. The point at which a rod end begins to yield is lower, in some cases dramatically lower, than the ultimate failure point, and is dependent upon the material and construction style selected, as well as the actual application parameters. Note that QA1's cataloged radial load ratings include a safety factor and insertion of a grease fitting into the radius of the rod end may reduce the load rating due to lesser cross-sectional material in the stressed point. The actual rating is determined by calculating the lowest of the following three values:

1. Race material compressive strength ( R Value ):  $R = E \times T \times X$
2. Rod end head strength ( H Value, cartridge type construction ):  $H = [ ( \frac{I}{2} \sqrt{D^2 - T^2} ) + ( \frac{D^2}{2} \times \sin^{-1} \frac{I}{D} ) - ( \text{O.D. of Bearing} \times T ) ] \times X$   
*Angle of  $\frac{I}{D}$  expressed in radians*
3. Shank strength ( S Value ) Male threaded rod end:  $S = [ ( \text{root diameter of thread}^2 \times .78 ) - ( N^2 \times .78 ) ] \times X$   
Shank strength ( S Value ) Female threaded rod end:  $S = [ ( J^2 \times .78 ) - ( \text{major diameter of thread}^2 \times .78 ) ] \times X$

Where: E = Ball Diameter  
T = Housing Width  
X = Allowable Stress ( See Table Below )  
D = Head Diameter  
N = Diameter of Drilled Hole in Shank of Male Rod End  
J = Shank Diameter of Female Rod End

## Axial Static Load Ratings

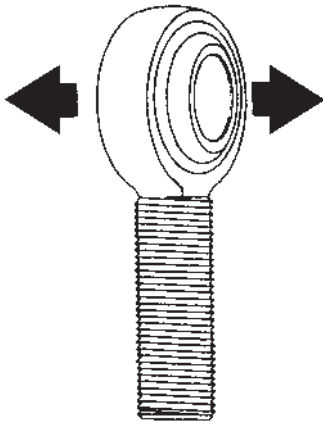

The axial static load capacity is measured as the force required to cause failure via a load parallel to the axis of the bore. Depending on material types and construction methods, the ultimate axial load is generally 10-20% of the ultimate radial static load. The formula does not account for the bending of the shank due to a moment of force, nor the strength of the stake in cartridge-type construction. **Rod ends are not designed for axial loads.**

Axial strength ( A Value ):  $A = .78 [ ( E + .176 T )^2 - E^2 ] \times X$

Where: E = Ball Diameter  
T = Housing Width  
X = Allowable Stress ( See Table )

Material	Allowable Stress (PSI)
Brass	30,000
Aluminum Bronze	35,000
300 Series Stainless Steel	35,000
Low Carbon Steel	52,000
Alloy Steel	140,000

## Angle of Misalignment

The maximum angle of the ball in a rod end or spherical bearing that can be maintained without interference is calculated as the angle of misalignment. It is defined as the angle between the ball centerline and the outer member centerline when the ball is aligned in its extreme position as allowed.

The worst case limiting angle is determined by clevis-mounted assembly as seen in Figure 1. Total misalignment under this condition, as cataloged by QA1 for rod end applications, is twice the angle from one side of center to the opposite extreme position.

Misalignment in a spherical bearing is limited by ball and race width, as functions of ball diameter and is illustrated in Figure 2 below. This calculation is the basis for QA1 cataloged angles of misalignment.

Other mounting arrangements as shown in Figures 3 and 4 can also be used as guidelines in calculating the precise angle of misalignment depending on the mounting configuration and are frequently referenced for metric usage.

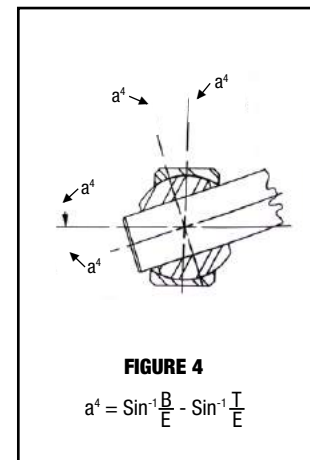
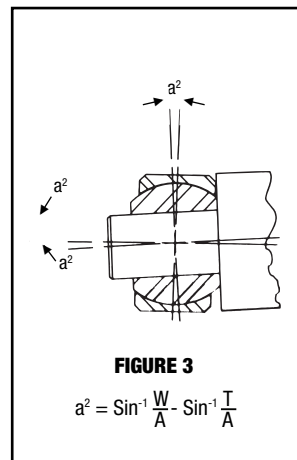
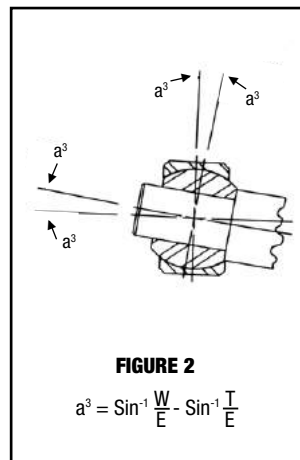
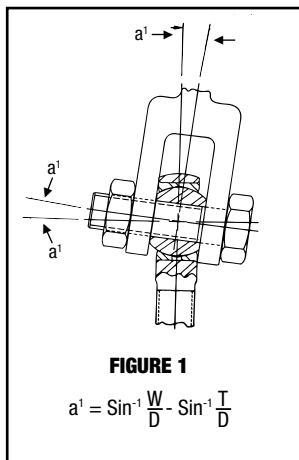

### Reference Letters

**B** = Ball Bore

**M** = Outer Race Chamfer

**D** = Head Diameter of the Outer Race Diameter

**E** = Ball Diameter

**T** = Housing Width

**A** =  $\sqrt{(D - 2M)^2 + T^2}$

**W** = Ball Width

# Inch & Metric Conversion Table

### Inch/Metric Conversion Table

Inch Fraction	Inch Decimal	MM Decimal	Inch Fraction	Inch Decimal	MM Decimal	Inch Fraction	Inch Decimal	MM Decimal	Inch Fraction	Inch Decimal	MM Decimal
	0.0004	0.001	17/64	0.2656	6.746		0.6693	17.0		1.3780	35.0
	0.0009	0.010		0.2756	7.0	43/64	0.6719	17.066		1.4173	36.0
	0.0010	0.025	9/32	0.2812	7.1437	11/16	0.6875	17.4625	1-1/2	1.5000	38.1
	0.0020	0.051	19/64	0.2969	7.5406	45/64	0.7031	17.859		1.5354	39.0
	0.0030	0.0762	5/16	0.3125	7.9375		0.7086	18		1.5748	40.0
	0.00394	0.1		0.3150	8.0	23/32	0.7187	18.256		1.6535	42.0
	0.0050	0.1270	21/64	0.3281	8.334	47/64	0.7344	18.653	1-3/4	1.7500	44.45
	0.00984	0.25	11/32	0.3437	8.731		0.7480	19.0		1.7717	45.0
	0.0100	0.254		0.3543	9.0	3/4	0.7500	19.05		1.8898	48.0
1/64	0.0156	0.396	23/64	0.3594	9.1281	49/64	0.7656	19.446		1.9685	50.0
1/32	0.0312	0.793	3/8	0.3750	9.525	25/32	0.7812	19.843	2	2.0000	50.8
	0.03937	1.0	25/64	0.3906	9.9219		0.7874	20.0		2.0472	52.0
3/64	0.0469	1.191		0.3937	10.0	51/64	0.7969	20.240		2.1654	55.0
	0.0591	1.5	13/32	0.4062	10.318	13/16	0.8125	20.6375		2.2047	56.0
1/16	0.0625	1.5875	27/64	0.4219	10.716		0.8268	21.0	2-1/4	2.2500	57.15
5/64	0.0781	1.984		0.4331	11.0	53/64	0.8281	21.034		2.3622	60.0
	0.0787	2.0	7/16	0.4375	11.1125	27/32	0.8437	21.431	2-1/2	2.5000	63.5
3/32	0.0937	2.381	29/64	0.4531	11.509	55/64	0.8594	21.828		2.5197	64.0
	0.0984	2.5	15/32	0.4687	11.906		0.8661	22.0	2-3/4	2.7500	69.85
	0.1000	2.54		0.4724	12.0	7/8	0.8750	22.225		2.8346	72.0
7/64	0.1094	2.778	31/64	0.4844	12.303	57/64	0.8906	22.621		2.9528	75.0
	0.1181	3.0	1/2	0.500	12.7		0.9055	23.0	3	3.0000	76.2
1/8	0.125	3.175		0.5118	13.0	29/32	0.9062	23.018		3.1496	80.0
	0.1378	3.5	33/64	0.5156	13.096	59/64	0.9219	23.416	3-1/4	3.2500	82.55
9/64	0.1406	3.571	17/32	0.5312	13.493	15/16	0.9375	23.8125	3-1/2	3.5000	88.9
5/32	0.1562	3.968	35/64	0.5469	13.891		0.9449	24.0		3.5433	90.0
	0.1575	4.0		0.5512	14.0	61/64	0.9531	24.209	3-3/4	3.7500	95.25
11/64	0.1719	4.366	9/16	0.5625	14.2875	31/32	0.9687	24.606		3.9370	100.0
	0.1772	4.5	37/64	0.5781	14.684		0.9843	25.0	4	4.0000	101.6
3/16	0.1875	4.7625		0.5906	15.0	63/64	0.9844	25.003	4-1/4	4.2500	107.95
	0.1969	5.0	19/32	0.5937	15.081	1	1.000	25.4		4.3307	110.0
13/64	0.2031	5.159	39/64	0.6094	15.478		1.0630	27.0	4-1/2	4.5000	114.3
7/32	0.2187	5.556	5/8	0.6250	15.875		1.1024	28.0		4.7244	120.0
15/64	0.2344	5.953		0.6299	16.0		1.1811	30.0	4-3/4	4.7500	120.65
	0.2364	6.0	41/64	0.6406	16.271	1-1/4	1.2500	31.75	5	5.0000	127.0
1/4	0.2500	6.35	21/32	0.6562	16.668		1.2992	33.0	5-1/2	5.5000	139.7

### Conversion Factors

Inches	x 25.4	= Millimeters
Millimeters	x .03937	= Inches
Sq. Inches	x 6.4515	= Sq. Centimeters
Sq. Centimeters	x .155	= Sq. Inches
Pounds	x .4536	= Kilograms
Kilograms	x 2.2046	= Pounds

Lbs. per in. <sup>2</sup>	x .0703	= Kg per cm <sup>2</sup>
Kg per cm <sup>2</sup>	x 14.2231	= Lbs. per in. <sup>2</sup>
Pounds (Force)	x 4.448	= Newtons
Newtons	x .2248	= Pounds (Force)
Degrees C = (Degrees F - 32) x .5556		
Degrees F = (Degrees C x 1.8) + 32		

# Suggested Housing Bores

Technical Information

# QA1

## COM & HCOM Series

Suggested Housing Bore for Press Fit of Spherical Bearings

DIMENSIONS IN INCHES

DIMENSIONS IN MILLIMETERS

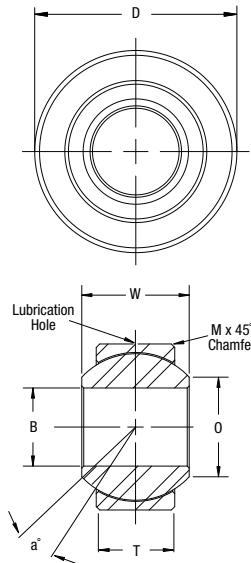

COM Numerical Part #	D + .0000 - .0007	STEEL HOUSING		ALUMINUM HOUSING	
		MAX.	MIN.	MAX.	MIN.
3	0.5625	0.5619	0.5614	0.5618	0.5612
4	0.6562	0.6556	0.6551	0.6555	0.6549
5	0.7500	0.7494	0.7489	0.7493	0.7487
6	0.8125	0.8119	0.8114	0.8118	0.8112
7	0.9062	0.9056	0.9051	0.9055	0.9049
8	1.0000	0.9994	0.9989	0.9993	0.9987
9	1.0937	1.0931	1.0925	1.0930	1.0923
10	1.1875	1.1869	1.1863	1.1868	1.1861
12	1.4375	1.4369	1.4363	1.4368	1.4361
14	1.5625	1.5619	1.5613	1.5618	1.5611
16	1.7500	1.7494	1.7488	1.7493	1.7487
<b>HCOM</b>					
16	2.0000	1.9994	1.9988	1.9993	1.9985
19	2.3750	2.3744	2.3736	2.3743	2.3735
20	2.3750	2.3744	2.3736	2.3743	2.3735
24	2.7500	2.7494	2.7489	2.7493	2.7485
28	3.1250	3.1244	3.1236	3.1243	3.1235
32	3.4994	3.4986	3.4994	3.4993	3.4985

COM Numerical Part #	D + .000 - .018	STEEL HOUSING		ALUMINUM HOUSING	
		MAX.	MIN.	MAX.	MIN.
3	14.288	14.272	14.260	14.270	14.255
4	16.667	16.652	16.640	16.650	16.634
5	19.500	19.035	19.022	19.032	19.017
6	20.638	20.622	20.610	20.620	20.604
7	23.018	23.002	22.990	23.000	22.985
8	25.400	25.385	25.372	25.382	25.367
9	27.780	27.765	27.750	27.762	27.744
10	30.162	30.147	30.132	30.145	30.127
12	36.512	36.497	36.482	36.495	36.477
14	39.688	39.672	39.657	39.670	39.652
16	44.450	44.435	44.414	44.432	44.412
<b>HCOM</b>					
16	50.800	20.785	50.764	50.782	50.762
19	60.325	60.310	60.289	60.307	60.287
20	60.325	60.310	60.289	60.307	60.287
24	69.850	69.835	69.814	69.832	69.812
28	79.375	79.360	79.339	79.357	79.337
32	88.900	88.885	88.864	88.882	88.862

## MIB, AIB & SIB Series

Suggested Housing Bore for Press Fit of Spherical Bearings

DIMENSIONS IN INCHES

DIMENSIONS IN MILLIMETERS

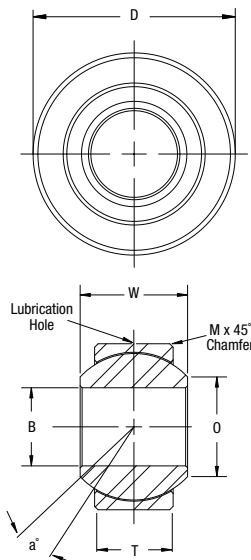

MIB, AIB & SIB Numerical Part #	D + .0000 - .0007	STEEL HOUSING		ALUMINUM HOUSING	
		MAX.	MIN.	MAX.	MIN.
3	0.5312	0.5306	0.5301	0.5305	0.5299
4	0.6094	0.6088	0.6083	0.6087	0.6081
5	0.7500	0.7494	0.7489	0.7493	0.7487
6	0.8437	0.8431	0.8426	0.8430	0.8424
7	1.0000	0.9994	0.9989	0.9993	0.9987
8	1.0937	1.0931	1.0925	1.0930	1.0923
10	1.3125	1.3119	1.3113	1.3118	1.3111
12	1.5000	1.4994	1.4988	1.4993	1.4986
14	1.6250	1.6244	1.6236	1.6243	1.6235
16	2.1250	2.1244	2.1236	2.1243	2.1235

MIB, AIB & SIB Numerical Part #	D + .000 - .018	STEEL HOUSING		ALUMINUM HOUSING	
		MAX.	MIN.	MAX.	MIN.
3	13.492	13.477	13.465	13.475	13.460
4	15.479	15.464	15.451	15.461	15.446
5	19.500	19.035	19.022	19.032	19.017
6	21.430	21.415	21.402	21.412	21.397
7	25.400	25.385	25.372	25.382	25.367
8	27.780	27.765	27.750	27.762	27.744
10	33.338	33.322	33.307	33.320	33.302
12	38.100	38.085	38.070	38.082	38.064
14	41.275	41.259	41.239	41.257	41.237
16	53.975	53.960	53.939	53.957	53.937

### RADIAL STATIC LOAD CAPACITY

These loads are maximum static based on maximum permanent set in the bearing race of 0.2% of the ball diameter.

### AXIAL STATIC LOAD CAPACITY

These loads are approximately 20% of the radial loads listed when the load bearing surfaces are properly supported.

### ALTERNATE RACE AND BALL MATERIALS

Materials other than those listed can be incorporated in QA1 bearings. Stainless steel is used to improve corrosion resistance and heat treated alloy steel is used to increase wear life. PTFE lined races are also available in this series to provide service requiring no re-lubrication and improved frictional characteristics. Tables are representative of metal-to-metal parts, please consult QA1 regarding PTFE lined parts.

# Product Interchange Guide

### Male Rod Ends

PAGE #	QA1	ALINABAL	AURORA	TUTHILL	SEALMASTER	HEIM	FK
8, 9	XM						KMX
10	AM*		ALM, XALM	KCA, KCAX			
21	NM	PM	SPM, SPB	NM, SPM	CTMD	CMHD	NJM
12	CM	AM	CM, CB	MSM	CFM	M-CR	CM
13	CM-T	AMT	VCM, VCB	MSM-T	CFM-T		CM-T
15	PCYM-T				UNIQUE TO MARKET		
14	PCM		CAM, CAB	MAX, XMAX			CMX
14	PCM-T		VCAM, VCAB	MAX-T, XMAX-T			CMX-T
11	GM-T		SM-T, SB-T	SSM-T			SCM-T
16	HM		AM, AB	TSMX, RMX	ARE	HMX	JMX
17	HM-T		AM-T, AB-T	TSMX-T, RMX-T			JMX-T
18	KM	RM	MM, MB	MTSM, RM	TRE		JM
19	KM-T	RM-T	MM-T, MB-T	MTSM-T, RM-T			JM-T
20	VM	VM, VXM		MBM	TM	HM, HM-C	M-SB
22	MXM				UNIQUE TO MARKET		
24	MCM		CM-M, CB-M	EM-M			CM-M
23	MGM-T					SME	SCM-MT
25	MHM		AM-M, AB-M				
26	MHM-T		AM-MT, AB-MT			SME	
27	MVM			DBM		SM, SMG	

### Female Rod Ends

PAGE #	QA1	ALINABAL	AURORA	TUTHILL	SEALMASTER	HEIM	FK
8, 9	XF, EXF						
10	AF*						
21	NF	PF	SPW, SPG	NF, SPF	CTFD	CFHD	NJF
12	CF	AF	CW, CG	MSF	CFF	F-CR	CF
13	CF-T	AFT	VCW, VCG	MSF-T	CFF-T		CF-T
15	PCYF-T				UNIQUE TO MARKET		
11	GF-T		SW-T, SG-T	SSF-T			SCF-T
16	HF		AW, AG	TSFX	AR		JFX
17	HF-T		AW-T, AG-T	TSFX-T			JFX-T
18	KF		MW, MG	MTSF	TR		JF
19	KF-T		MF-T, MG-T	MTSF-T			JF-T
20	VF	VF, VXF		MBF	TF	HF, HF-C	F-SB
22	MXF				UNIQUE TO MARKET		
24	MCF		CW-M, CG-M	EF-M			CF-M
23	MGF-T					SFE	SCF-MT
25	MHF		AW-M, AG, M				
26	MHF-T		AW-MT, AG-MT				
27	MVF			DBF		SF, SFG	

### Spherical Bearings

PAGE #	QA1	ALINABAL	AURORA	TUTHILL	SEALMASTER	HEIM	FK
31	COM	COM-E	COM	COM	COM	COM, LHA	COM
31	COM-T	COM-T	COM-T	COM-T			COM-T
31	COM-SS		COM-E		COR	LHSS	
31	HCOM		HCOM		BH-LS	LH-D	COMH
32	WPB-T		PWB-T	WSSB		WE	WSSX-T
33	NPB-T		PNB-T	NSSB		NE	FKSSX-T
33	YPB-T		HAB-T	YSSB			HIN-T
34	MIB, AIB, SIB		MIB, AIB, SIB				
35	MCOM		COM-M				

**NOTICE:** All above listed interchanges are approximate and do not indicate that all products are functionally interchangeable in all applications. Users are advised to consult with the manufacturer to assist in determining suitability for use. QA1 assumes no liability for the use of the above interchange.

# Part Number Reference Guide

Technical Information

# QA1

## Rod End & Spherical Bearing Part Number Reference Guide

At QA1, we want you to find the right part quickly and easily. That's why our rod end and spherical bearing part numbers are designed to help you identify the main features of each product immediately, without needing product descriptions.

### What Do the Letters Mean?

The first thing to look for in the part number is the series name (C, G, COM, etc.). From there you can determine threads, sizes, and more just by looking at the rest of the part number.

The table to the right highlights the letters that signify identifying features of the products as well as the meaning of each. These will appear in the order they're shown. Note that S and Z are available options that can be added to the end of the part number.

Letter	Meaning
M	Metric
C, H, COM, etc.	Series
Y	High Misalignment
M/F*	Male or Female*
R/L*	Right or Left Hand*
#	Size
T	PTFE Lined
S*	Studded*
Z*	Grease Fitting*

\*Rod ends only

### Determining the Size in Inch and Metric Products

Our sizes also reflect the actual measurements. In inch series, the number represents the number of 1/16"; so, a size 8 would be 8/16" (or 1/2"), while a 6 would be 6/16", or 3/8". In metric series, the number of the size is the number of millimeters. So, a size 6 is 6mm. In inch series, our sizes range from 2 (1/8") to 32 (2"); in metric, they range from 5 (5mm) to 20 (20mm) in rod ends and to 30 (30mm) in spherical bearings.

Size Number	Inch	Metric
2	1/8"	-
3	3/16"	-
4	1/4"	-
5	5/16"	5mm
6	3/8"	6mm
7	7/16"	7mm
8	1/2"	8mm
9	9/16"	9mm
10	5/8"	10mm
11	11/16"	11mm
12	3/4"	12mm
13	13/16"	13mm
14	7/8"	14mm
15	15/16"	15mm
16	1"	16mm
17	1 1/16"	17mm

Size Number	Inch	Metric
18	1 1/8"	18mm
19	1 3/16"	19mm
20	1 1/4"	20mm
21	1 5/16"	21mm
22	1 3/8"	22mm
23	1 7/16"	23mm
24	1 1/2"	24mm
25	1 9/16"	25mm
26	1 5/8"	26mm
27	1 11/16"	27mm
28	1 3/4"	28mm
29	1 13/16"	29mm
30	1 7/8"	30mm
31	1 15/16"	-
32	2"	-

### Examples

Below are some examples of our identification system using the G series of rod ends and the COM series of spherical bearings. If you have any questions, please call 1-800-721-7761.

### Rod End Example

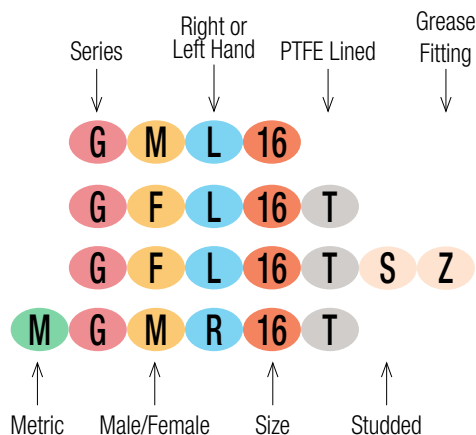

### Spherical Bearing Example

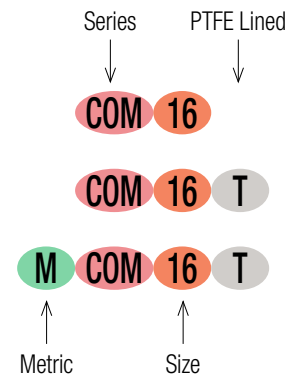

## CALIFORNIA PROPOSITION 65

### WHAT IS CALIFORNIA PROP 65?

In 1986, California voters approved an initiative to address their growing concerns about exposure to toxic chemicals. That initiative became the Safe Drinking Water and Toxic Enforcement Act of 1986, better known by its name of Proposition 65.

Recent changes to the law have updated the product labeling requirements for product sold in California. Warning labels must accompany any product that contains or may contain any of the chemicals appearing on the list administered by California's Office of Environmental Health Hazard Assessment (OEHHA).

### WHAT DOES THIS MEAN FOR THE PRODUCTS IN THIS CATALOG?

Proposition 65 imposes strict penalties for noncompliance and the list of chemicals is so expansive that it is cost-prohibitive for a small company to go through the individual testing process for each product that is offered. As a result, QA1 Precision Products, Inc. (QA1) is taking a conservative approach and labeling all products with the warning as required by Proposition 65. This does not mean that we believe our products are harmful when used as designed. QA1 is committed to the safety and protection of our customers and will apply warning labels either on the product or the product packaging, of all products currently offered for sale. QA1 products may contain one or more of the listed chemicals in a smaller amount than Proposition 65's concern, or not at all, however we have chosen to issue this warning on all products as an act of extreme caution and because our customers have the right to know.



**CALIFORNIA PROPOSITION 65**  
**WARNING:**  
**CANCER AND REPRODUCTIVE HARM**  
**WWW.P65WARNINGS.CA.GOV**

### ADDITIONAL RESOURCES

For more information about Proposition 65 visit:

<https://oehha.ca.gov/proposition-65/general-info/proposition-65-plain-language>

## Technical Support

QA1 is dedicated to providing quality support and instructions for all of our products. For any of your product needs, we have technical tips and installation guides on our website, [www.QA1.net](http://www.QA1.net), along with downloadable information you can use away from your computer as you work on your application. Our YouTube channel, [www.youtube.com/QA1TECH](http://www.youtube.com/QA1TECH), also has many tech, product and company videos.

If you can't find the answer you are looking for, feel free to give us a call at 1-800-721-7761. Our technical support and order lines are open Monday through Friday, 8 am to 5 pm CST.



## How to Order Custom Products

In order to help you create the best product possible, it's helpful to have as much information as possible. Below are some common questions that we generally ask in the first stages of product development in order to help determine how we can help you create a product that fits your needs perfectly.

### To start your development program for a custom project, please determine:

- Load ratings needed for your particular application
- Target price
- Desired quantity
- Desired timeline for production
- Whether the product will be in a static or dynamic environment; if dynamic, determine an approximate speed of motion
- Environmental conditions in which the product will be used (engineering concerns will differ greatly for the same product being used in a warehouse versus at the bottom of the ocean)
- Expected or desired lifespan

Once the above have been addressed, contact QA1 at 1-800-721-7761. QA1's engineers will then work closely with you to come up with drawings of the product to best achieve your desired results. Once the drawings are approved, we can begin manufacturing samples before moving on to the final testing and production.

### To start your development program for custom composite material products, please determine:

- Desired annual quantity
- Target price
- Desired timeline for production
- Product's shape (i.e. round, square, rectangular)
- Rough size of the project (i.e. If round, determine both the inner and outer diameter as well as the length of individual pieces)
- Loading type - torque, bending, compression, tension
- Strength requirements
- Weight requirements
- Additional requirements – i.e. end fixtures or components, materials, testing requirements, temperature requirements

Once the above have been addressed, contact QA1 at 1-800-721-7761. QA1's engineers will then work closely with you to determine the best production process for your product.

### To start your development program for shock absorbers, please determine:

- Target price
- Installed lengths, compressed and extended, for your application
- Type of desired mounting for installation. Options include eyelet mounts, studs, T-bars, and specialty brackets
- Desired quantity
- Desired timeline

Once you've made these determinations, contact QA1 at 1-800-721-7761. QA1's engineers will then work closely with you to fit and develop the best shock absorber for your application(s).





# Terms & Conditions

All information contained herein is subject to change without notice.

## TERMS

Prepaid, Visa, MasterCard. Net 30 Days from the invoice date terms are available after credit approval. Accounts with invoices past due will be placed on "Credit Hold" and orders will not be shipped until the account is made current. A finance charge of 1.5% per month will also be applied to all past due invoices, not to exceed the maximum charge permitted by law. All collection expenses will be the responsibility of the Purchaser. Accounts are considered paid in full upon QA1's receipt of the full invoice amount plus collection fees and expenses incurred, if any. NSF checks, stop payment checks, chargebacks on credit cards, etc. are charged a minimum \$25 fee. No deduction or credit may be taken for any reason unless a credit memo has been issued by QA1. Any unauthorized deduction will automatically put the account on credit hold. Special and custom orders require a 50% down payment. In the event of Purchaser using freight collect or 3rd party billing for freight, the Purchaser is ultimately liable for and agrees to pay all charges if said freight is billed back to QA1 for any reason. QA1 reserves the right to modify payment and credit terms from time to time and may require advance payment in full or security for payment of any order for the Products.

PO's submitted by Purchaser to QA1 for any customized or Purchaser-unique products already received at QA1, on order, in transit for delivery, or otherwise procured in good faith against Purchaser's PO's may not be cancelled. Upon Purchaser's written request, QA1 will make reasonable efforts to accommodate changes to delivery schedules. However, such adjustments may be subject to additional costs or charges and may not go beyond 120 calendar days. Commercial-off-the-shelf product PO's from Purchaser that do not exceed special order volume minimums may be amended from their original issuance but only after receipt of Purchaser's written PO change request and written acceptance/reply from QA1.

## DAMAGED SHIPMENTS / SHORTAGES

All QA1 shipments are F.O.B. our factory. Title passes from QA1 to the purchaser at the time of shipment. Carton shortages and damages must be claimed against the carrier at the time of delivery. To expedite processing of claims against the carriers, the purchaser must note damages on the bill of landing at the time of delivery, and promptly request an inspection by the carrier or its claims agent. If a shortage is found within the shipment it must be reported to QA1 in writing within five (5) business days of receipt of shipment. Claims should refer to the order number, invoice number, date of invoice, date of shipment, part number, description and carton count.

## DROP SHIPMENTS & REFUSED PACKAGES

Drop shipments are charged a \$20 service charge. A 20% restocking fee and all shipping costs are charged to the ordering party if a package is refused. No international drop shipments.

## FREIGHT

QA1 ships via UPS as standard. Other shipment methods may be used when shipping via UPS is not practical or possible. For truck shipments only, purchasers may specify a particular carrier when purchaser is paying freight.

## RETURNS

QA1 will issue a R.M.A. for every return, including sample Purchaser parts for quoting. Returns will not be accepted without the R.M.A. number. All authorized returns must have the R.M.A. number on all cartons and shipping documents. Returned product must be shipped prepaid, regardless of what separate policy Purchaser may have, collect shipments will be refused. Modified, installed, damaged, or used products are not eligible for return under any circumstance as the end user has the final choice in the fitment and suitability for the intended use of the product. For commercial-off-the-shelf QA1 products that do not exceed special order volume minimums, returns made within 90 days after the invoice date are subject to a 20% restocking charge. No returns are accepted after 90 days. No returns are accepted for Purchaser-unique products. Freight charges are not refundable unless the merchandise is defective as determined by QA1. Special orders are not returnable.

## WARRANTY / DISCLAIMER

QA1 warrants that the products will be free from defects in material and workmanship for one year from date of sale to the original purchaser. QA1 makes no other warranty of any kind, express or implied. QA1 shall have no obligation under the foregoing warranty where the defect is the result of improper or abnormal use, negligence, accident, improper or incorrect installation or maintenance, nor when the product has been repaired or altered in any way. QA1's liability in the case of defective products subject to the foregoing warranty shall be limited to the repair or replacement, at QA1's option, of the defective products. QA1 will be the sole judge of warranty claims. QA1 does not authorize anybody else to determine warranty claims. Consequential or incidental damages are not recoverable under this warranty. Some states do not allow the exclusion or limitation of incidental or consequential damages, so the above limitation or exclusion may not apply to you. This warranty gives you specific legal rights, and you may also have other rights which vary from state to state. In order to be eligible for service under this warranty, you must return the defective part to QA1 with an R.M.A. number issued from QA1. Tag each item with the part number and the specific explanation of defect. We will inspect the part and determine: a) if it is eligible for repair or replacement; and, b) if so, whether to repair or replace it.

All returns must be shipped prepaid to:  
QA1 Precision Products, Inc.

RMA # \_\_\_\_\_  
9574 217th St. W. Lakeville, MN 55044

THE PURCHASER UNDERSTANDS AND EXPRESSLY RECOGNIZES that all parts and services sold by QA1 are exposed to many and varied conditions due to the manner in which they are installed and used. PURCHASER ACKNOWLEDGES that QA1 does not have full knowledge of the intended use of the goods, and PURCHASER WILL DEFEND AND INDEMNIFY QA1 upon demand against all claims, actions, liability, loss and expense (including investigating expense and attorney fees incurred in litigation or because of threatened litigation) for any loss, damage or injury, either to a person or to property, resulting from the direct or indirect use of any QA1 products or inability by the buyer to determine proper use or application of QA1 products. With the exception of the limited liability warranty set forth above. QA1 SHALL NOT BE LIABLE FOR ANY CLAIMS, DEMANDS, INJURIES, DAMAGES, ACTIONS, OR CAUSES OF ACTION WHATSOEVER TO BUYER ARISING OUT OF OR CONNECTED WITH THE USE OF ANY QA1 PRODUCTS.

For complete terms and conditions of sale, please visit our website at [www.QA1.net](http://www.QA1.net).

